



**DFR 1250**

**PAPERLESS RECORDER**

**USER'S GUIDE**

# CONTENTS

|   |           |
|---|-----------|
| <b>1.0 INTRODUCTION</b> .....                           | <b>1</b>  |
| 1.1 Chart Speed to Sample Speed .....                   | 2         |
| 1.2 Reviewing Data .....                                | 2         |
| 1.3 Zooming and Conditioning Data.....                  | 2         |
| 1.4 Customizing .....                                   | 2         |
| 1.5 Triggering .....                                    | 3         |
| 1.6 The Graphics LCD Display .....                      | 3         |
| 1.7 Other Graphic Modes .....                           | 4         |
| <b>2.0 INSTALLATION AND SETUP</b> .....                 | <b>5</b>  |
| 2.1 Unpacking.....                                      | 5         |
| 2.1.1 <i>Initial Inspection</i> .....                   | 5         |
| 2.1.2 <i>Unpacking Procedure</i> .....                  | 5         |
| 2.1.3 <i>Detected Damage</i> .....                      | 5         |
| 2.1.4 <i>Equipment Return</i> .....                     | 5         |
| 2.1.5 <i>Storage</i> .....                              | 6         |
| 2.2 Installation .....                                  | 6         |
| 2.2.1 <i>Panel Mounting</i> .....                       | 6         |
| 2.3 Connection .....                                    | 7         |
| 2.3.1 <i>Power Connections</i> .....                    | 7         |
| 2.3.2 <i>Input Signal Connections</i> .....             | 8         |
| 2.3.3 <i>Relay Output Connections</i> .....             | 9         |
| 2.3.4 <i>Digital Input</i> .....                        | 9         |
| 2.3.5 <i>USB Port (Option)</i> .....                    | 10        |
| 2.3.6 <i>ETHERNET Port (Option)</i> .....               | 10        |
| 2.3.7 <i>Isolated DC input (Option)</i> .....           | 10        |
| 2.3.8 <i>Cleaning</i> .....                             | 10        |
| 2.4 Input Scaling .....                                 | 10        |
| 2.5 Alarms .....  | 11        |
| 2.5.1 <i>Alarm Types</i> .....                          | 11        |
| 2.5.2 <i>Setting</i> .....                              | 11        |
| 2.5.3 <i>Alarm Indication</i> .....                     | 12        |
| 2.6 Memory Cards .....                                  | 12        |
| 2.6.1 <i>Care of the Data Cards</i> .....               | 12        |
| 2.6.2 <i>Card Storage Capacity and Data Type</i> .....  | 12        |
| <b>3.0 BASIC OPERATING INSTRUCTIONS</b> .....           | <b>13</b> |
| 3.1 Basic Mode of Operation.....                        | 13        |
| 3.2 Viewing Historic Data .....                         | 13        |
| 3.3 Compressing and Expanding Data (Trend Viewing)..... | 13        |
| 3.4 Zooming Data (Amplification).....                   | 14        |
| 3.5 Menu Mode .....                                     | 14        |
| 3.5.1 <i>Exit!</i> .....                                | 14        |
| 3.5.2 <i>Alarm Reset!</i> .....                         | 15        |
| 3.5.3 <i>Record Mode</i> .....                          | 15        |
| 3.5.4 <i>Cursor ID!</i> .....                           | 15        |
| 3.5.5 <i>View File</i> .....                            | 15        |
| 3.5.6 <i>Card Status!</i> .....                         | 16        |
| 3.5.7 <i>Sample Rate</i> .....                          | 16        |
| 3.5.8 <i>Password (Protection)</i> .....                | 16        |
| 3.5.9 <i>Adv. Setup (Advanced Setup)</i> .....          | 16        |

|  |           |
|--|-----------|
| 3.5.10 Display Adj (Adjust) .....                        | 16        |
| 3.6 Event Triggering .....                               | 17        |
| 3.7 Status Line Indicators .....                         | 17        |
| 3.8 Entering Data.....                                   | 17        |
| 3.9 Top Level Menu Overview .....                        | 19        |
| <b>4.0 ADVANCED SETUP .....</b>                          | <b>20</b> |
| 4.1 Channel Setup.....                                   | 20        |
| 4.2 Alarms .....   | 21        |
| 4.3 Relays .....   | 22        |
| 4.4 Display .....  | 22        |
| 4.5 Data Card .....                                      | 23        |
| 4.6 Clock .....  | 24        |
| 4.7 Beeper.....  | 24        |
| 4.8 Sample Trigger.....                                  | 25        |
| 4.9 Record Trigger .....                                 | 25        |
| 4.10 External Input.....                                 | 25        |
| 4.11 Unit Tag.....                                       | 25        |
| 4.12 Comms.....  | 25        |
| <b>5.0 MISCELLANEOUS.....</b>                            | <b>26</b> |
| 5.1 Battery Backup Option .....                          | 26        |
| 5.2 Ethernet Option .....                                | 26        |
| 5.3 Calibration .....                                    | 27        |
| 5.3.1 Basic Calibration.....                             | 27        |
| 5.3.2 Examples .....                                     | 28        |
| 5.4 Specifications.....                                  | 29        |
| <b>APPENDIX A - UNITS LABEL CHARACTERS.....</b>          | <b>31</b> |
| <b>APPENDIX B - ERROR AND INFORMATION MESSAGES .....</b> | <b>31</b> |
| <b>APPENDIX C - MASTER RESET.....</b>                    | <b>31</b> |
| <b>APPENDIX D – RE-PROGRAMMING FIRMWARE.....</b>         | <b>32</b> |
| <b>WARRANTY REPAIR POLICY .....</b>                      | <b>32</b> |

## SAFEGUARDS AND PRECAUTIONS

Read and follow all instructions in this manual carefully, and retain this manual for future reference.

Do not use this instrument in any manner inconsistent with these operating instructions or under any conditions that exceed the environmental specifications stated.

This instrument is not user serviceable. For technical assistance, contact Cooper Instruments (800-344-3921).

### WEEE NOTICE



**In order to comply with EU Directive 2002/96/EC on Waste Electrical and Electronic Equipment (WEEE):**

This product may contain material which could be hazardous to human health and the environment. DO NOT DISPOSE of this product as unsorted municipal waste. This product needs to be RECYCLED in accordance with local regulations, contact your local authorities for more information. This product may be returnable to your distributor for recycling - contact the distributor for details.

### Para obedecer con EU Directiva 2002/96/EC en el Desecho el Equipo Eléctrico y Electrónico :

Este producto puede contener la materia que podría ser la salud humana perjudicial para y el ambiente. NO se DESHAGA de este producto el desecho municipal como no clasificado. Estas necesidades del producto para SER RECICLADAS de acuerdo con las regulaciones locales, contactan su administración local para más información. Este producto puede ser retornable a su distribuidor para reciclar - contacta el distribuidor para detalles.

### Afin de respecter la directive européenne 2002/96/EC sur l'Équipement Electronique et les Déchets Electriques :

Ce produit pourrait contenir des matières qui peuvent être dangereuses pour la santé de l'homme et de l'environnement. Ne pas jeter ce produit dans un container municipal inapproprié. Ce produit doit être recyclé en accord avec les arrêtés locaux; contacter les autorités locales pour plus de renseignements. Ce produit peut être renvoyé au distributeur pour recyclage - Contacter votre distributeur pour plus de details.

### Um den Vorschriften der EU-Direktive 2002/96/EC bezüglich elektrischer und elektronischer Abfallstoffe nachzukommen:

Dieses Produkt kann Materialien enthalten, welche gesundheitsgefahrdend und umweltschädlich sind. Dieses Produkt DARF NICHT wie unsortierter Hausmuell entsorgt werden. Dieses Produkt muss gemaess den oertlichen Bestimmungen recycled werden, bitte kontaktieren Sie die lokalen Behoerden fuer weitere Informationen. Sie koennen dieses Produkt zum Recycling an Ihren Haendler zurueckgeben, bitte kontaktieren Sie den Haendler fuer weitere Details.

## 1.0 INTRODUCTION

This instrument is a versatile Solid State Data Recorder / Panel Indicator. It has all the capability of a traditional paper recorder - variable chart speeds, the ability to review historic data, see trends and more, with a number of specific exceptions - *NO PAPER to jam, no ink to smudge and no pens to clog or break*. The data is stored in a Compact Flash memory card, which can be easily transported.

Of course it does all the regular functions a lot better, and the data can be transferred directly into reports, spreadsheets or analysis programs. Data can be examined and archived on any Windows XPTM compatible machine and can be printed out in various formats as required.

This instrument has two *universal inputs* so it can measure voltage, current, thermocouples and RTDs by simply selecting them from the menu. It also has two potential free alarm output contacts and an isolated digital input. The display can be user configured to graphics, digital or a combination. Maximum data storage is 2 Gigabytes. Communication options include USB and Ethernet ports.

Things are done a little differently in a paperless recorder and there are a few new concepts that you may need to become familiar with. There are more features and functions in this unit than you will probably use. It is recommended that you read this manual in its entirety before attempting to use the instrument.

The balance of this introduction will attempt to introduce some of the more unique features of this paperless recorder.

### **1.1 Chart Speed to Sample Speed**

A major difference between paper and paperless is SAMPLE SPEED, which is analogous to CHART SPEED in the paper recorder. There *is* an apparent chart speed, the rate at which the samples appear to move across the Graphics Display, but unlike paper recorders the display is made up of discrete data points, each of which is a distinct sample of the data being measured. The rate of movement across the screen is thus a direct function of the sample rate. The major factor in deciding what sample rate to select is knowing how much data is enough. In a paper recorder a chart speed of 1 inch per hour is fine for a process that does not vary very quickly but would result in a thick blur if trying to record a 1Hz sine wave. Unlike a paper recorder, every point recorded by the paperless recorder is uniquely identifiable, no matter how dense it appears on the screen. It is always better to have too much data than to have too little. The only consideration is the amount of space used in the memory card.

To relate chart speed to sample rate we need to consider how we plan to reproduce the data. The graphic LCD display has a density of 70 pixels (data points) per inch; a typical dot matrix printer has 180 pixels per inch and a laser printer 300 pixels per inch. Thus to fill one inch of the display in one hour we need to sample at a rate of 70 samples per hour, a little over once per minute, however if this is now printed on a laser printer it will fill less than 1/3 of an inch. It is the amount and quality of the data that counts. Another advantage of the paperless recorder is that it can sample internally at 100 samples per second (one every 0.01 seconds). These samples can be averaged or peaks or valleys can be detected and then this data can be stored at the chosen sample rate.

Trial and experience will yield the best sample speeds for the application. Start with a faster sampling rate than you think you will need; you can always slow it down in the future. As a rule of thumb, one sample every 10 seconds should give the equivalent information that 1 inch per hour of chart paper would.

### **1.2 Reviewing Data**

One of the biggest features of this recorder is its ability to show historic data and trends. The data on the graphics screen can be rewound like a tape recorder, scrolling back in time, displaying past data on the screen while still recording data in real time.

The data can also be compressed on screen, showing a whole day or week's worth of recording on one screen, enabling trends or irregularities to be spotted easily. A data cursor can be moved around the screen to uniquely identify samples in both time and amplitude.

Refer to the Section 3 for the specifics on reviewing data.

### **1.3 Zooming and Conditioning Data**

The recorder acquires data with greater resolution than can be displayed on the screen. The user has the ability to ZOOM in to amplify the data either 2 or 4 times, equivalent to using a magnifying glass on the display. These ZOOM windows can be scrolled up or down to cover the entire data spectrum. The vertical scale automatically adjusts to the zoom level and position to enable resolution of minor changes in input signal.

The recorder also acquires data at a rate faster than what may be displayed on the screen. The user can set the sampling rate from 100 samples per second down to 1 sample every 10 minutes. When sampling slower than 100 samples per second, the recorder can be programmed to record the average, maximum or minimum values. Thus if a sample rate of 1 sample per minute is chosen, the recorder will still sample internally at 100 samples per second while computing the average or detect and store either the maximum (peak) value or minimum (valley) value, depending on the mode programmed. It will then store this value when the minute is up. Unless required otherwise, it is recommended that the average value be used for recording since this will tend to filter or smooth the data. See Advanced Setup Menu for details.

### **1.4 Customizing**

There are many operating features and parameters that the user can program. All settings are stored in nonvolatile memory and are recalled each time the unit is powered on. The display can be scaled to read in engineering units, and the trace can be labeled accordingly with up to three alphanumeric characters. Four alarms are fully user

programmable and can be associated with either channel or the external input. The Alarm levels can be set in the engineering units of the display, the sense of the alarm, the type and the deadband or hysteresis can be individually set for each alarm. Optional relay outputs can be assigned independently to each alarm. A reset delay feature is also available.

There are other features which may be programmed by the user including the time stamping mode, either real time or elapsed time, clock update rates, file names, beeper operation etc. (Refer to – Advanced Setup)

### 1.5 Triggering

The recorder has the ability to change sampling speeds and stop or start recording as a result of a triggered event. This event may be tied to any of the four internal alarms or optionally to an external signal. This enables the unit to monitor a process without recording or to record at a slow speed to conserve card space. When an external event or internal alarm condition occurs, the unit will begin recording or change to a higher sample rate for the data of interest.

### 1.6 The Graphics LCD Display

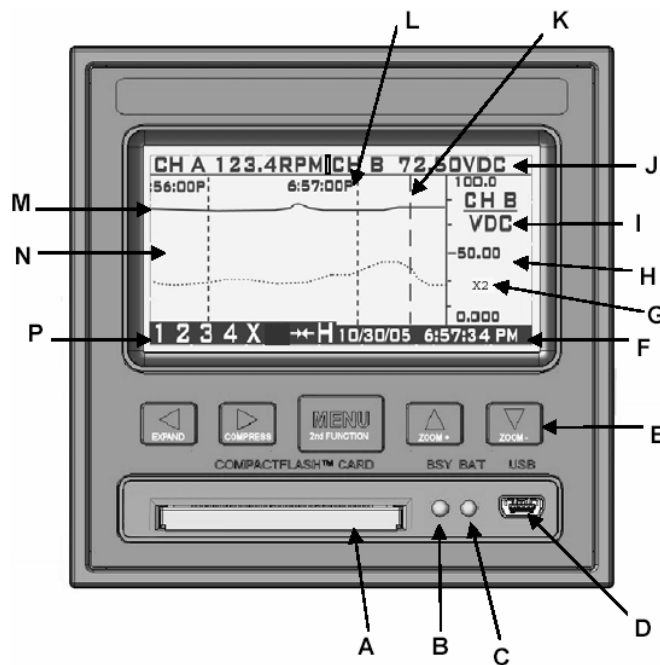

**Recorder Front View showing TREND Display**

The above diagram is a representation of the recorder in the TREND mode. The alpha characters around the border point to various features of the unit and are described below. Not shown are the MENUS which pop up over the display. The menus are in the form of those shown in Sections 4 and 5. The numbers in parenthesis below refer to the section that covers the topic in detail.

- A** CompactFlash™ card slot – manually insert a card into the unit to store data and configuration information. Can also be used as a means of updating the firmware in the unit. Cards up to 2 Gigabytes in size can be used.
- B** Busy LED (Red) – on when the unit is recording and blinks rapidly whenever the unit is accessing the CompactFlash™ card. Blinks at 1 second rate if unit is triggered but not recording. Do not attempt to remove the card when this light is on.
- C** Power LED (Green) – on during normal operation. If the optional internal battery pack is present, this LED will blink during power failure to indicate the unit is running off internal batteries.
- D** Optional USB interface – enables connection to a Windows XP compatible PC.

- E** Navigation buttons – used to set up and navigate around the display. The buttons are all dual function; the second function is initiated by holding down the MENU button while pressing one of the other buttons. The second function is printed on each button.
- F** Date and Time – shows the actual time of day (real time). The time is displayed user selectable in 12 or 24 hour format. The user can also select European or American formats and auto daylight savings adjustment. See Clock setup.
- G** Zoom Scale Indicator – shows the zoom scale for the channel indicated if > x1. Separate scale for each channel. See zooming.
- H** Right hand edge of the graphics area in which the traces are displayed. This is the vertical scale area designated by the scale values at the top, center and bottom of the scale. The most recent data that is displayed in digital form at the top of the display (J) is against the right edge of this scale and moves left with time - the most recent data is to the right and the oldest data is to the extreme left. New data appears against this margin and the oldest data disappears off the screen at the extreme left. The graphic cursor (K) will start against this right edge.
- I** Vertical Scale Identifier – this display alternates between Channel A and Channel B. It displays the Channel Tag and the Engineering units. See Channel setup.
- J** Digital Window – the top of the screen displays the values for each Channel including the Channel identifier, the current value and the engineering units. Channel A is displayed on the left and Channel B on the right. This window displays the absolute digital value of the instantaneous (last) reading for the channel, and is the right most sample value on the trend display (G), unless the cursor is active. In that case it shows the value at the point the cursor intersects the trend line.
- K** Cursor – is displayed when activated in the cursor ID mode. This cursor can be moved using the left ◀ and right ▶ arrow buttons. The values in the digital window (J) are the values at the point where the cursor intersects the trend line.
- L** Date/Time Axis Delimiter – the dotted vertical lines placed at equal increments along the Horizontal axes (Time). The Date/Time stamp beside the line indicates the exact position of the line. Both date and time may be shut off or relocated vertically. These lines move with the trace at a speed dependent on the sampling speed. This is configurable in Display Setup.
- M** Channel B Trace – the trend line is the graphic representation of Time (horizontal) versus Amplitude (vertical) and is shown solid to distinguish it from the Channel A trace, which is shown as a dotted trend line. This is configurable in Display Setup.
- N** Graphic TREND Window – shows the channel traces, which may be compressed, expanded, zoomed, scrolled and halted.
- P** Status Icons – these icons appear at various times to indicate the status of the unit and the display. From left to right they are:
  - The numbers **1,2,3** and **4** are the ALARM indicators - one for each alarm. The numbers are present when the alarm is enabled and will blink if the alarm is in an alarm condition.
  - The X indicates the status of the EXTERNAL INPUT and is present when the external input is present.
  - The  icon indicates the display is compressed. The horizontal time stamps indicate the current compressed values. The display can function normally in compressed mode, may be paused or the user can scroll back and forth using the left ◀ and right ▶ arrow buttons.
  - The H indicates the display is in the HOLD condition. While in HOLD, the trends do not update. The display enters the HOLD condition when the ID Cursor (K) is present or the user scrolls in the horizontal direction using the left ◀ and right ▶ arrow buttons. Exit the HOLD mode by pressing the MENU button.



**DO NOT INSERT OR REMOVE THE COMPACT FLASH CARD WHILE THE BUSY LED IS ON!**

### **1.7 Other Graphic Modes**

In addition to the full screen trend mode shown section 1.6, there are two additional graphic display modes.

The Dual Digital mode, as shown below, enables both channels to be shown as Digital values similar to a digital panel meter. The user has the option of showing the displays in normal or reverse video (shown) modes, and the display can be set to blink on Alarm Condition.

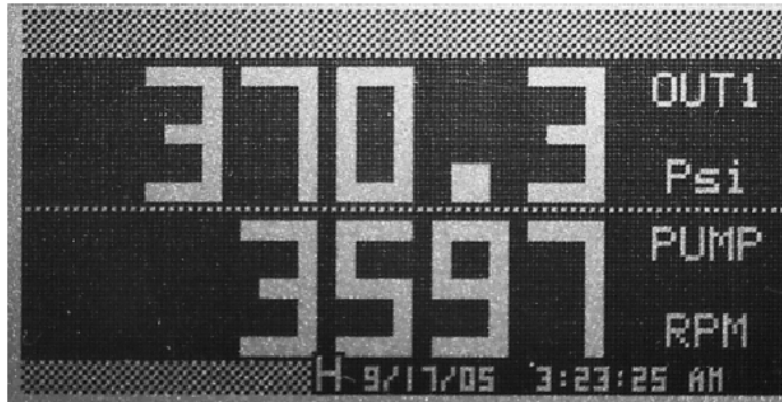

The other Graphic mode is a split screen with the trend in the top half and the digital display in the lower half as shown below. When selecting this mode, Channel B is the default digital value, but can be switched in the Advanced Setup menu.

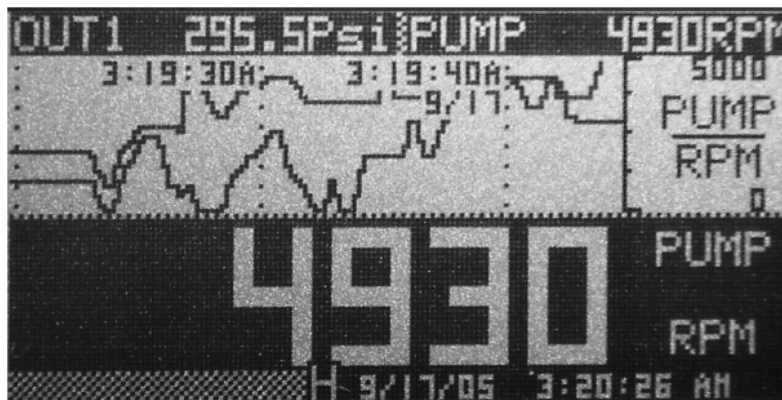

## 2.0 INSTALLATION AND SETUP

### 2.1 Unpacking

#### 2.1.1 Initial Inspection

Exercise care when unpacking the instrument from the shipping carton. The instrument is packed in a custom cardboard box to prevent damage during normal transit. If damage to the shipping carton is evident, ask the carrier's representative to be present when the instrument is unpacked.

#### 2.1.2 Unpacking Procedure

To unpack your Recorder, first remove the cardboard retainer and instrument from the shipping carton. Check the box for the following contents - The Recorder, two locking bars, two 6-32 x 1/2" screws, AC power supply wall unit (unless the unit is the isolated DC model) and this manual.

#### 2.1.3 Detected Damage

Remove the instrument from the plastic bag and check for damage if any. Also check that the unit is as ordered. If damage is detected after unpacking the instrument, immediately report any damage to the shipping agent and re-pack the instrument for return it to the factory as described in the following section.

#### 2.1.4 Equipment Return

Before returning a damaged or malfunctioning instrument to the factory for repair, contact the sales organization from which you purchased the instrument. A Return Merchandise Authorization (RMA) number must be obtained from the factory before returning an instrument for any reason.



### 2.1.5 Storage

For prolonged storage before installation, re-pack the Recorder in the shipping container and store in a cool, dry area. We do not recommend storage of the Recorder for more than one year. If longer storage time is required, contact the factory for additional storage information.

## 2.2 Installation

The instrument is intended to operate in the following environment:

### Indoor Use Only

**Installation Category II** per IEC 664

**Pollution Degree Level II** per IEC61010-1

**Temperature** -10 °C to 50 °C operating per IEC61010-1

**Humidity** Maximum relative humidity 80% for temperatures up to 31 °C decreasing linearly to 50% relative humidity at 40 °C

**Recorder Power** 9.0 +0.5V dc @ 5VA (unless indicated otherwise on the unit)

**AC Power Requirement (External adapter)** 100 - 240 Vac ~ 50/60 Hz

**NOTE:** The recorder is designed to be panel mounted and as such should be considered as permanently connected. Disconnection from the supply must be possible via a customer supplied switch or circuit breaker. This disconnection device must be included in the panel installation and should be clearly marked, it must be in close proximity to the Recorder and easily accessible to the operator.

**NOTE:** In order to fully comply with the CE EMC Directive 89/336/EEC, connections to the recorder should not exceed 3m (9.8ft) without adding additional filtering.

The Recorder fits in a standard ¼ DIN panel cutout of 92 x 92 mm (3.62 x 3.62 in.) and requires 140mm (7.5 inches) panel depth not including space for power and input source cable. The thickness of the panel is immaterial, but panels thicker than .125 inch will require that the locking bars be cut down. Actual dimensions are shown below in Figure 2.1:

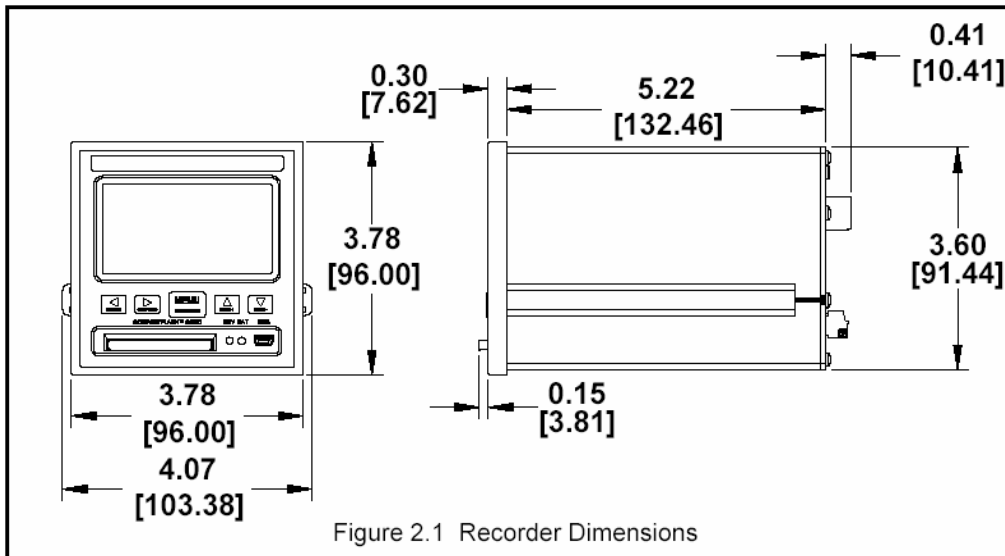

**WARNING: Do not use this instrument in any manner inconsistent with these operating instructions or under any conditions that exceed the environmental specifications stated.**

### 2.2.1 Panel Mounting

The Recorder should be mounted in a vertical panel to ensure proper operation. Ensure you have the proper clearances and proceed as follows:

2.2.1.1 Cut a panel opening 96 mm x 96 mm (3.62 x 3.62 in.).

- 2.2.1.2 Remove any packaging material from the Recorder. Always handle the unit carefully to avoid damaging the LCD display or scratching the display surface.
- 2.2.1.3 Remove the locking bars from the Recorder enclosure by removing the captivating screws
- 2.2.1.4 Insert the Recorder, rear end first, through to front of the panel opening.
- 2.2.1.5 With the Recorder held firmly in place against the panel, install one of the locking bar assemblies from the rear, by sliding the locking bar tongue into the groove on the side of the Recorder enclosure as shown in Figure 2.2.
- 2.2.1.6 Insert the retaining screw into the rear of the groove. Using a Phillips screwdriver, tighten the screw until the locking bar is just pressing against the panel.
- 2.2.1.7 Install the other locking bar assembly into the groove on the opposite side of the Recorder enclosure and tighten as before.
- 2.2.1.8 Using the screwdriver, tighten both screws so that the Recorder is held firmly in place. Do not over tighten, to avoid stripping the threads.

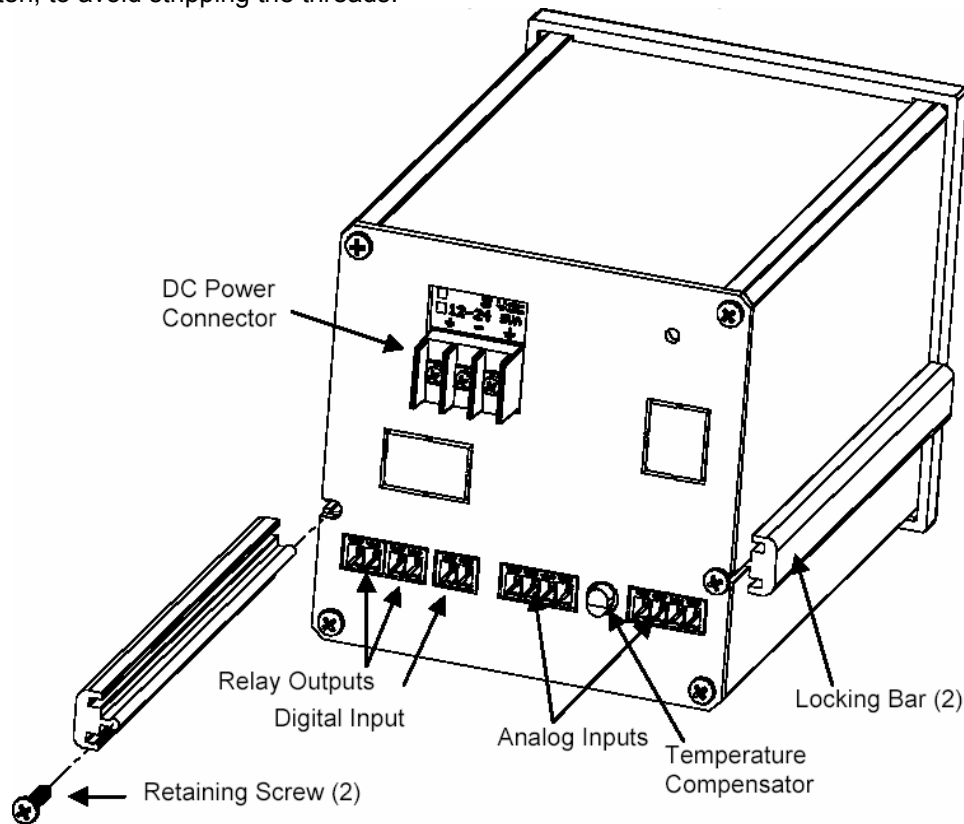

**Figure 2.2 Rear View - Installation**

## 2.3 Connection

### 2.3.1 Power Connections

**WARNING** NOTE: The Recorder is designed to be panel mounted and power should be considered to be permanently connected. Disconnection from the supply must be possible via a customer supplied switch or circuit breaker. This disconnection device must be included in the panel installation and should be clearly marked, in close proximity to the Recorder and easily accessible to the operator.



**THE RECORDER IS DESIGNED TO OPERATE ON 9 Vdc. DO NOT CONNECT AC POWER DIRECTLY TO THE UNIT AT ANY TIME.**

The power connector is located on the rear panel in the top left corner. There are two voltage options available for the recorder – the standard is 9Vdc, which is used with an external universal AC Mains power supply. The external wall power supply is a high efficiency switcher that will work from 100 to 240 Volts AC 50/60 Hz. The other power option is an isolated 12 to 24Vdc input for use with an external DC power supply. The power supply option is marked with a dot in a square on a label above the power connector as shown in Figure 2.3. Check the unit to ensure that the power and inputs are as expected.

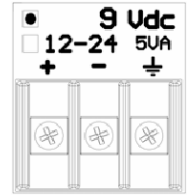

Figure 2.3

Before connecting any power or inputs to the unit, ensure that all signal wires and power cables are at zero voltage. The DC power is applied to the unit via a three-way screw terminal connector. The power supply is supplied with two tinned leads, the positive lead is identified by the RED shroud over the wire. The third connection is for system GROUND. You will require a small flat-head screwdriver. Connect the power and signal wires accordingly, noting carefully all polarities. **Ensure that the unit is properly grounded** to a suitable ground within the cabinet.

Loosen the screws on the terminal block and insert the exposed conductor cable from the power supply below the screws, under the metal plate. Ensure that the insulation is flush with the terminal block. If it is too long, remove the cable, trim and reinsert. Tighten the screw to firmly hold the cable. Ensure the ground wire is connected and properly grounded at the other end. If you are not using the supplied wall power supply, follow the same procedure carefully identifying the positive supply line. The unit is protected against reverse polarity but not against substantial over voltage.

### 2.3.2 Input Signal Connections

**WARNING** The maximum input on any input channel is 25 Volts DC. Voltages higher than this may permanently damage the unit.



Ensure the unit is powered down before connecting any inputs.

There are two universal analog inputs – Channel A and Channel B. Each is programmed independently of the other. Inputs can be voltage or current (50mA max using an external shunt), thermocouples, RTDs or TTL compatible pulse inputs. Isolation is provided between inputs and the rest of the system. The channels are not isolated from each other. Connection detail for the various inputs is shown in Figure 2.4.

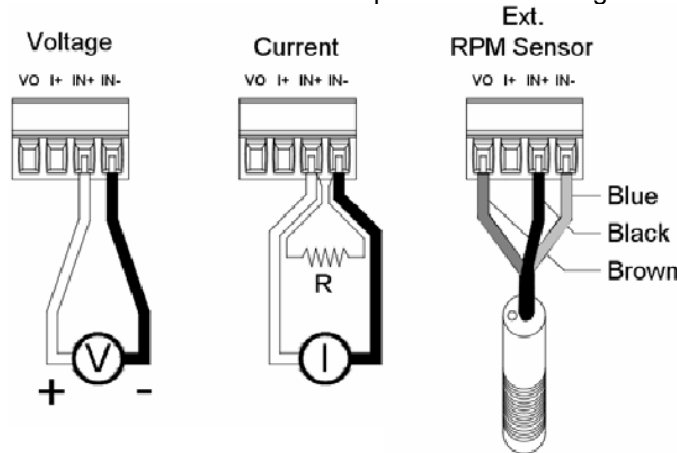

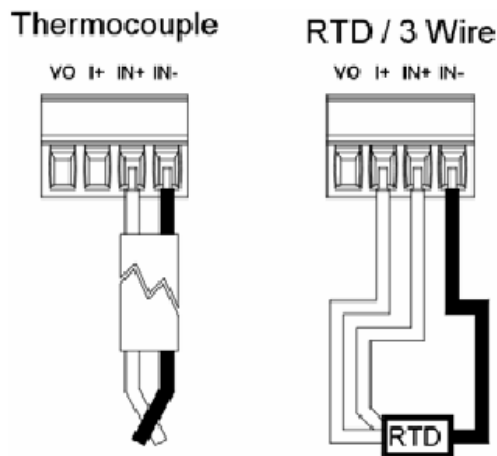

**Figure 2.4 - Connection Detail**

When connecting the signal wires, keep polarities correct. The screw terminals are marked on the rear panel - there are four connections per channel. The high or positive signal marked IN+, and a low or common signal marked IN-. The terminal marked Vo is the Auxiliary voltage output used to drive external sensors at +5Vdc and a maximum of 50mA. The terminal marked I+ is the 1mA current required for RTDs or resistors. Any screen or shield (often the braided wire) should connect directly to the system ground and is used to shield the low level input signals from induced noise pick up.

Connect the signal wires to the terminal block in the manner described above. Use wire of adequate gauge to carry the signal. The mA input requires the use of an external 250 ohm shunt (Check with supplier). Thermocouples should be connected with thermocouple wire of the same type as the input; the terminal block is the reference junction. Connect any sheath or braid to the GROUND connection. RTDs have an additional wire, the current source, which is connected to the terminal marked I+. See Figure 2.4.

**WARNING: Unused inputs must have IN+ and IN- commoned together.**

**CAUTION: Never run signal and power or control wiring together in the same conduit. This practice will prevent possible recording error due to induced signals between lines. Route signal wires away from power wires at the rear panel.**

**NOTE: Ground cable shields at one end only to eliminate the possibility of interference due to ground loop currents. When grounded transducers are used, the shield should be grounded at the sensor end only.**

### 2.3.3 Relay Output Connections

**WARNING**



**To prevent the possibility of electrical shock, use extreme caution when wiring contact output connections. Hazardous potentials may exist on contact output terminals that are floating with respect to instrument ground. WIRES FROM REMOTE SOURCES MAY CONTAIN DANGEROUS POTENTIALS. ENSURE ALL POWER SOURCES ARE DISCONNECTED BEFORE WIRING RELAY CONTACTS.**

The relay contacts are rated for AC or DC operation (Maximum recommended voltage - 30 Volts.) Each relay has a set of potential free contacts. There is no polarity to the terminals; it is a normally open contact that closes in alarm condition. These contacts are internally suppressed for EMI/RFI and High Voltage transients resulting from inductive loads. The relays may be programmed as fail safe, which means they are energized in the "off" condition. This way if the power should fail the relays will open into the alarm condition. See note below.

### 2.3.4 Digital Input

The digital input is optically isolated and is activated by an external dc supply of 5 to 12Vdc at 20mA. The input is via the DIGITAL INPUT + and - terminals. The - connection is the COMMON for the external input, while the + is the input for the positive voltage.

The digital input may be used as an External Trigger to stop or start recording, or may be used to change the sampling speed. Thus the unit can be set to record only when a conveyor is running for example. The External Trigger may also be linked internally to the optional Relay Output. This could be used as a remote "record active" indicator. Refer to Sections on Relay setup and External Input setup.

**Note:** In order to fully comply with the CE EMC Directive 89/336/EEC cables to the relay output and digital input should be looped through a ferrite (Type Steward 28R2025-0R0 or similar) close to the terminals.

### **2.3.5 USB Port (Option)**

The USB Port is an option and will be installed only if specifically ordered. It is a serial connection to a PC that allows the user to program the recorder remotely, start or stop recording and download real time data.

Refer to the separate manual that is supplied with the USB interface option.

### **2.3.6 ETHERNET Port (Option)**

The Ethernet Port is an option and will be installed only if specifically ordered. It allows the user to program the recorder remotely, start or stop recording and download real time data. The IP address is set in the Advanced SETUP Menu Refer to the separate manual that is supplied with the Ethernet interface option.

### **2.3.7 Isolated DC input (Option)**

The unit may be powered by an external DC source with the isolated DC to DC option. Connect the unit to the external DC source and observe the voltage and polarity of the inputs. In order to fully comply with the CE EMC Directive 89/336/EEC the power cable should be looped through the ferrite bead provided, close to the terminals.

### **2.3.8 Cleaning**

The unit may be cleaned by wiping with a soft cloth. The front panel and display / keypad may be wiped with a slightly damp soft cloth containing soapy solution or a mild detergent. Do not use any lemon based (citric acid) product to clean the display / keypad. NOTE: THE UNIT IS NOT WATERTIGHT.

## **2.4 Input Scaling**

The input to the recorder is often a standard process variable (e.g. voltage) rather than the actual units being measured (e.g. pressure).

There are a number of custom conversions available in the unit to take care of special inputs such as thermocouples and RTDs, which need special scaling and linearization. These are preset in the unit and require no modification. There is also the capability to customize any input variable that has a linear relationship to the measured variable. The relationship between the required variable and the input variable must satisfy the equation for a straight line:

$$y = mx + b$$

where  $y$  is the output value to be displayed and recorded,  $x$  is the input variable (typically volts or milliamps DC),  $m$  is the scale factor (slope of the line) which defines the relationship between the input and the displayed variable and is a constant (linear relationship), and the factor  $b$  (known as the  $y$  intercept) is a constant offset variable that may be positive or negative.

This facility to scale the input is found in the ADVANCED SETUP menu and is available to each channel independently. Here the user can easily scale the input and set the displayed units using three alphanumeric characters.

The scaling is achieved in the unit in the CHANnel X SETUP option ( $X = A$  or  $B$ ) in the ADVanced SETUP menu. First set the displayed LO SCALE, which may be positive, negative or zero. Then set the displayed HI SCALE for the full-scale input. The unit will then automatically compute the scale factor and offset.

Setting the engineering units is done in the same menu location using the CHAN UNITS option to set the three alphanumeric characters.

Let us assume we have an input from a pressure transducer of 1 to 5 volts DC, corresponding to real world units of zero to 250 PSI (Pounds per Square Inch of pressure). Assume we choose the 0 to 5 volt input. The actual output span of the transducer is 4 volts, with 1 volt = 0 PSI and 5 volts = 250 PSI. This is equivalent to 62.5 PSI per volt. The LO SCALE which is the "0" volt value is equivalent to -62.5 PSI and should be set to this value, and the HI

SCALE is set to "250". The engineering units are set to "PSI". The display will now show zero to 250 PSI for 1 to 5 Volts input. The linear scaling is shown in Figure 2.5.

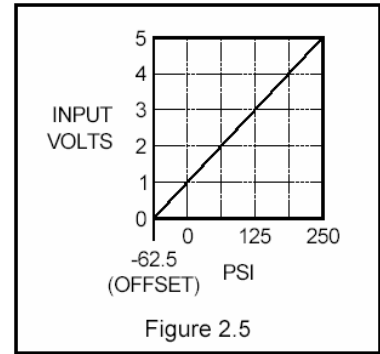

Figure 2.5

## 2.5 Alarms

The Recorder has four programmable internal alarms with dual relay output. The alarms can be associated with either analog input channel, can be set as high or low, latching or non-latching with or without lockout capability. Each relay has a set of potential free normally open contacts (Form A - SPNO) that are accessible from the rear panel via screw terminal connections. Alternatively the relays can be set to the failsafe mode, normally closed (Form B - SPNC). The relays can be assigned to any, all or none of the alarms. Refer to section on Alarms and Relays in Advanced Setup Menu.

### 2.5.1 Alarm Types

A **high** alarm is active when the input is greater than the setpoint. A **low** alarm is active when the input is less than the setpoint. A **latching** alarm will remain set once activated and must be **reset** by the operator. Note that the alarm condition should be removed before resetting the alarm or the alarm will activate and latch again. A **non-latching** alarm will set on alarm condition and automatically reset once the alarm condition is removed. A differential, known as hysteresis or **deadband** can be introduced so that once an alarm is set (at the setpoint), the input must go beyond the deadband before the alarm resets. This prevents the output relays from chattering in borderline conditions. The **deadband** is set in absolute units and adds to the setpoint in a low alarm, or subtracts from the setpoint in a high alarm. By way of example, if the setpoint is 100, the hysteresis (deadband) is set to 5, and the alarm is a high type and non-latching, then the alarm will activate when the input exceeds 100 and will remain active until the input drops below 95 (100 minus 5). Alternatively the user can set a **reset delay** from 1 to 255 seconds. This delay must time out once an alarm condition has been removed before the alarm will reset to normal.

**Lockout** prevents an alarm from activating until the setpoint has been traversed in the opposite sense by the input. For example, if we were measuring pressure and had a low alarm set at 100, we may not wish the alarm to be active on start up when the pressure may be low or zero. We really wish to monitor a low-pressure situation once our target pressure has been reached, say 150. The lockout prevents the alarm activating at startup. The alarm remains deactivated until the input exceeds the setpoint. Now the alarm arms and any future time that the input drops below the setpoint, the alarm will activate.

### 2.5.2 Setting

Setting and configuration is done in the **Advanced Setup Menu**.

The alarm setpoints are set in the same units as the input type and may be different for each channel. When setting the actual setpoint value, the value may be incremented in steps other than what is expected (unit steps). This is due to the fact that the input is converted into a digital value with a finite resolution. It is not possible to set a setpoint value that cannot be resolved by the internal microprocessor. Select the closest value to the exact value you require; it will always be with 0.5%. The same applies when setting the deadband.

Note that when configuring the alarms, there is no correlation between inputs, alarms and relay outputs. These are user defined. Each alarm can be assigned to only one input channel.

When setting up each alarm channel, the user should **DISABLE** the alarm so that parameters may be changed **WITHOUT AFFECTING THE RELAYS**. This is done in the **ALARMS** menu by selecting the **ENABLE** option so that no  $\surd$  appears to the left of this option. Once everything is set, select **ENABLE** once more to activate the alarm, indicated by the presence of the  $\surd$ . (Refer to Section on Setting Alarms)

- ⇒ When setting up alarms, you may get unexpected results from the relays if they are enabled. Ensure there is nothing connected to the relays that could result in an accident due to random closing of the relays during setup and always **DISABLE** the alarm as described above. Make the changes and then re-enable the alarm.

There are many different ways the alarms can be set up. All the alarms can be assigned to a single channel and may be of the same type giving for example a various degrees of high warning and ultimately a high shutdown

indication. Also, the relays may be assigned to any combination of alarms. This would allow a single relay output to indicate any alarm active. The combinations are endless.

### **2.5.3 Alarm Indication**

There are three indications of alarm condition: the relay outputs, visual icons on the display and audible alarm.

When an alarm is armed and functioning, it is indicated by a small "1", "2", "3" or "4" in reverse video on the bottom left hand side of the graphic display. These status indicators remain on as long as the alarm is enabled. If an alarm is triggered (in alarm condition), the status indicator will blink and the internal beeper will sound. The beeper can be permanently disabled from the Advanced Setup Menu - BEEPER - ALARMS - OFF.

The relays close on an alarm condition, assuming they have been set up correctly. The relays can be set as fail-safe by reversing the logic of the alarms (Advanced Setup Menu - RELAYS - FAILSAFE).

## **2.6 Memory Cards**

The memory cards used are standard CompactFlash™ cards. We recommend the use of **Sandisk™** CompactFlash™ cards. The cards are keyed and can only go into the recorder right side up. The largest capacity card that can be accommodated is 2 Gigabytes.

### **2.6.1 Care of the Data Cards**

Do not expose the cards to direct sunlight or extremes of temperature for any length of time. Do not expose to moisture. Do not bend or twist. Avoid high static discharge. Mail in suitable packaging to avoid postal damage. When transporting, use an anti-static bag or the plastic enclosure in which the card is supplied.

### **2.6.2 Card Storage Capacity and Data Type**

Depending on what else is stored on the card (e.g. configurations files, other data files), data storage capacity can be roughly calculated by the following formulas:

Number of samples is card size divided by 4.4. The time that it will take to fill a card is roughly the number of samples divided by the sample rate. For example, a 32MB card will hold roughly 32,000,000 divided by 4.4 = 7,272,727 samples. At 5 samples per second this is 1,454,545 seconds or 404 hours or approximately 16.8 days.

If you show the Card Status window (MENU - CARD STATUS), it will indicate how much time is left on the card. It also displays the current Filename that is being used for recording.

The files on the card are in DOS standard format and can be managed on any Windows™ based machine with a CompactFlash™ reader - internal or external. The content of the files is in proprietary binary format and requires special software to read the data. All units are supplied with the Navigator Lite Software, which allows the data to be exported to Excel.

This space intentionally left blank.

## 3.0 BASIC OPERATING INSTRUCTIONS

The Basic mode of operation encompasses those functions that would be done on a routine basis and relate primarily to viewing and reviewing data with some use of the menu system. The advanced mode, while technically still simple to operate, involves setting up the unit and would typically need to be done only once.

### 3.1 Basic Mode of Operation

Basic operations are all done using the five buttons on the front panel (shown below) and the first level menu.



Each arrow button has dual functions. The second function is activated by pressing and holding the **MENU** (2nd Function) button and then pressing any of the other buttons. The 2nd function of each button is denoted by the text under the arrow symbol. (EXPAND, COMPRESS, ZOOM + and ZOOM -).

The unit need not be recording to the memory card in order to manipulate data. The data available however is dependent on how long the unit has been operating, the sample rate and the buffer or memory card size.

### 3.2 Viewing Historic Data

Any data that is not currently visible on the screen is historic data. To view past data, the left (◀) and right (▶) arrow buttons are used to rewind (◀) or fast forward (▶) the data (scrolling). When rewinding, data will be retrieved from the memory card or from the internal buffer and is available as far back as the start of recording. When fast-forwarding, data is available up to real time. The time and date stamp on the screen indicates the relative time of the samples being viewed. Depending on the amount of data to process there may be delays before the screen reacts.

Historic viewing by scrolling is limited to the file (or files) created since recording was manually started via the RECORD MODE Menu - ON. If NOT recording, scrolling back in time is limited to the content of the internal buffer. The history buffered is dependent upon the sampling speed. Data is presented as latest data first.

It is possible to view data from other files of previously recorded data (or even data recorded on another machine) using the View File menu.

- ⇒ At any stage during the rewind or fast forward process, the screen can be restored to current or real time display by pressing the **MENU** button.
- ⇒ When the data on screen is not current, an **H** appears on the status line to indicate that the rewind or compress mode is active and the data is on **Hold**.

### 3.3 Compressing and Expanding Data (Trend Viewing)

In order to view data trends, it is often necessary to pack more data onto the screen than is normally visible in real time. To compress the data, press and hold the **MENU** (2<sup>nd</sup> Function) key and then press the COMPRESS (.) key. Each time this key is pressed the amount of data on the screen will double up to a maximum of 32 times (equivalent to 5 sequential key presses). Once compressed, data can be rewound and fast-forwarded as described in the previous section. The data can be expanded back after being compressed by pressing and holding the **MENU** key and then pressing the EXPAND (◀) button.

Note that compression displays peak values (both high and low). Thus even though data is compressed, all amplitude information is present on the display. At compressions of 16 times or greater, the redraw time of data on the screen slows down due to the large amounts of data that must be manipulated.

- ⇒ At any stage during the compression or expansion process, the screen can be restored to current or real time display by pressing the **MENU** button.
- ⇒ When the data on screen is compressed, a **⏮** appears on the status line to indicate that the compress mode is active.



### 3.4 Zooming Data (Amplification)

As a result of the small display area available, it is not always possible to see small changes in amplitude of the recorded signals even though the resolution of the internal converters can measure it. To overcome this problem you can ZOOM in on a portion of the graph and get increased resolution.

ZOOM applies to each channel independently. The trace that will zoom is the one whose scale is shown to the right. To adjust the other trace simply wait for its scale to appear.

To ZOOM in and amplify the graph, press and hold the **MENU** key, press the ZOOM+ (▲) button and then release both buttons. The display will zoom in by 2. Note that the scale units change to reflect the increased zoom level. There are three zoom levels available: x1, x2 and x4.

To decrease the zoom level (or zoom out), press and hold the **MENU** key, press the ZOOM- (▼) button and then release both buttons.

While adjusting the zoom, scale flipping is suspended. Turning the other trace off will also suspend flipping.

Note that when zoomed in at any zoom level, the (▲) and (▼) buttons will move the graph relative to the window enabling viewing of any part of the graph within the zoom window. When zooming, the trace expands or contracts about the centerline. If zooming drives the trace off the screen, it will automatically reposition itself at the top or bottom vertical edge of the chart. Once in a zoom level, all functions are operational on the zoomed display.

- ⇒ *When in a zoom mode, the zoom level is indicated in the lower half of the scale for the associated channel (X2, X4 etc.). No indication indicates normal scale (X1).*
- ⇒ *To exit the zoom mode, zoom out (MENU + ▼) as far as possible until the scale value disappears – x1 mode.*

### 3.5 Menu Mode

At any time when in normal view mode, pressing the **MENU** button will bring up the user menu as shown to the right. Note that the menu "pops up" over the graphics display. The unit continues to record and will not lose data. There is also a time out option that will return a menu display back to a graphic display after a period of inactivity. (Refer to Advanced Setup DISPLAY - MENU TIMEOUT).

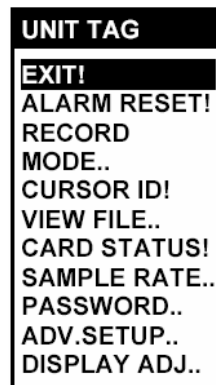

- ⇒ When the menu is active, the Left Arrow (◀) and Right Arrow (▶) buttons act as ESCAPE keys to return to a previous level without activating any function.

The user moves about the menu using the Up Arrow (▲) and Down Arrow (▼) buttons. The current selection is always highlighted in reverse. To select a function, simply move to it with the (▲) and (▼) buttons and then press the **MENU** button once. To go back a level without activating any function, simply press the (◀) or (▶) buttons. Note that the menu has more options than can be displayed at once on the screen. When a selection gets to the top or bottom of the menu list, the list will scroll until the last entry is reached then wrap around. Pressing and holding the (▲) and (▼) buttons will activate an Auto Repeat function and cause the highlight bar to scroll automatically.

The menu has multiple levels. An option with a secondary level is indicated by .. after the name. Access to the various levels can be controlled by a password (Refer below).

#### 3.5.1 Exit!

When the menu is displayed, it defaults to the **EXIT** selection. At this point, pressing the **MENU** button will return to the graphic display.

### 3.5.2 Alarm Reset!

Pressing the **MENU** button after selecting **ALARM RESET!** will reset any alarm that is active and latched and then exit the Menu Mode. If the alarm is not latched but is still in alarm, selecting this option will briefly reset the alarm, which will then activate again.

### 3.5.3 Record Mode..

To begin or end recording in the data card, press the **MENU** button, use the Up Arrow (▲) or Down Arrow (▼) button to highlight **RECORD MODE** and then press the **MENU** button again. Several options appear in a sub window: **OFF**, **ON** and **TRIGGERED**. To exit at this stage without changing the current setting, press either the Left (◀) or Right (▶) Arrow button. Otherwise, use the Up Arrow (▲) or Down Arrow (▼) button to make a selection and then press the **MENU** button. The active selection is indicated by a √ to the left of the option. If you are using the alarms or external input to control the recording, select **TRIGGERED** for triggered operation. **OFF** and **ON** will always stop or start a recording irrespective of the state of any of the record triggers. (Refer to Event Triggering.)

- ⇒ The RECORD MODE menu option may be password protected.
- ⇒ Before selecting **ON** or **TRIGGERED** to begin a recording, ensure that a Memory Card is in place and that there is sufficient space available to contain your new data. (Refer to *CARD STATUS* below.)

To return to the graphic screen, press either the Left (◀) or Right (▶) Arrow button. For further details on other options under RECORD MODE, refer to ADV. SETUP - DATA CARD.

**Note:** While recording, the recorder automatically switches to OFF when a card is removed, or if it is not present when power is applied. This will require a manual restart of the recording when a new card is inserted. If the card remains in the slot while power is removed the recorder restores the recording state it was in when the power was interrupted.

### 3.5.4 Cursor ID!

The Cursor ID mode enables the user to accurately pinpoint the time and amplitude of any sample in the graphics window. The unit has to be in the full graphic mode for this option to work.

To enable this function, press the **MENU** button, use the Up Arrow (▲) or Down Arrow (▼) button to highlight **CURSOR ID!** and then press the **MENU** button again. The Menu will vanish revealing the Graphics screen and a single data cursor against the right edge of the display area. **Note: The Cursor ID mode will not activate if the Trend is compressed.** The screen will be in the HOLD mode and the data window at the top of the screen and time/date stamp at the lower right will show the values of the samples under the data cursor. The status line will show the highlighted  to indicate that the data and timestamp is that of the data under the cursor and not real time data.

Using the Left (◀) or Right (▶) buttons the user can move the data cursor to the point of interest. The data window at the bottom of the screen will show the time and date of the sample and the digital readings at the top of the screen - A (and B in dual channel units) show the absolute value. Note that at the extremities of the data, the cursor hits an end point and then the data scrolls beneath it. This method can be used to accurately identify unique points on the graphics display no matter how busy the traces appear.

To return to normal (real time) mode, press the **MENU** button. Note that entering the Cursor ID mode does not affect the real time acquisition of data.

### 3.5.5 View File

The user can view data from files other than the one currently being recorded. The View File option allows the user to view previously recorded data on the data card from the very first file through to the current data. The display HAS TO BE IN THE FULL GRAPHIC MODE for this to work.

To view a file on the memory card, press the **MENU** button, use the Up Arrow (▲) or Down Arrow (▼) button to highlight **VIEW FILE** and then press the **MENU** button again. The current filename will be displayed. To view historic data from this file, simply press the **MENU** button. To choose a different file on the memory card, press the

Left Arrow (◀) button twice to display a directory listing of all files on the card. Then use the Up Arrow (▲) or Down Arrow (▼) button to highlight the desired file and press the **MENU** button twice to select it.

When viewing from a file, the status line will show a highlighted **F** to indicate that the data being viewed is from a File on the memory card. All View, Compress and Zoom functions work on the prerecorded file. Use the Left (◀) or Right (▶) buttons to move through the file. Data will be presented as oldest samples first.

To return to the current real time trend, press the **MENU** button. View File will automatically abort if the data card is removed.

### **3.5.6 Card Status!**

To display the status of the memory card, press the **MENU** button, use the Up Arrow (▲) or Down Arrow (▼) button to highlight **CARD STATUS!** and then press the **MENU** button again. A pop-up window will be displayed showing information about the memory card including the size of the card, the amount of space left as a percentage and the equivalent record time at the current settings.

To remove the Card Status pop-up window, select **CARD STATUS!** again.

### **3.5.7 Sample Rate**

To adjust the sample rate (the rate at which data is recorded and displayed), press the **MENU** button, use the Up Arrow (▲) or Down Arrow (▼) button to highlight **SAMPLE RATE** and then press the **MENU** button again.

⇒ The **SAMPLE RATE** menu option may be password protected.

When entering the **SAMPLE RATE** menu, the rate highlighted is **the current sampling rate**. To exit at this stage without changing the current setting, press either the Left (◀) or Right (▶) button. In this manner the user can check the current sampling rate at any time without affecting the recording.

To change the sampling rate, use the Up Arrow (▲) or Down Arrow (▼) button to highlight the desired sample rate and then press the **MENU** button. The sample rates vary from a high of 100 S/sec (Samples per second) to the slowest 10 min/S (minutes per sample, sec/S is seconds per sample).

To return to the graphic screen, press either the Left (◀) or Right (▶) button.

### **3.5.8 Password (Protection)**

To set, reset or change a password, press the **MENU** button, use the Up Arrow (▲) or Down Arrow (▼) button to highlight **PASSWORD** and then press the **MENU** button.

⇒ This menu option may be password protected.

Follow the prompts. Enter a 4-digit password using a combination of ◀▶▼▲ buttons. The key presses are echoed in a pop-up window and roll around, first in first out. Once you have entered your password, press the **MENU** button.

If you are entering a new password, you will be asked to repeat your password and then press the **MENU** button. At this point the password is entered and the unit is protected.

To clear the password, enter the current password and then simply press the **MENU** button when prompted to enter the new password. A null password is no password at all.

### **3.5.9 Adv. Setup (Advanced Setup)**

See Section 4.

### **3.5.10 Display Adj (Adjust)**

To adjust the backlight brightness and viewing angle, press the **MENU** button, use the Up Arrow (▲) or Down Arrow (▼) button to highlight **DISPLAY ADJ** and then press the **MENU** button again.

Adjust the Viewing Angle using the ◀ and ▶ keys and the Backlight Intensity using the ▲ and ▼ keys. Press the **MENU** button to accept the changes and exit.

### 3.6 Event Triggering

The recorder has the ability to be triggered by certain events that are generated internally or, optionally, externally, which will enable it to automatically change sampling speed or begin or end a recording session. The trigger can be any alarm or the external input. The user can thus set the unit to record at a slow sample speed until some alarm condition is triggered and then change to a higher sample rate to record the transient. Another example is the use of the external event trigger to start and stop recording allowing the selective recording of specific events.

The event triggering is setup in the Advanced Setup Menu option. The control of recording, stopping and starting is set in the **REC. TRIG.** (Record Trigger) menu option (Section 4.9), while the changing of sample speed is controlled via the **SAMPLE TRIG**ger menu option where a second set of sample speeds will be presented for the triggered speed change (Section 4.8). This rate may be slower or faster than the regular rate depending on application.

The external event may be used in the same manner as the internal alarms for triggering a change of speed or record status. The external event trigger characteristics are set in the **ADV. SETUP - EXT. INPUT** menu option.

If the recorder is triggered but not recording, the red LED will blink at a 1 second interval.

### 3.7 Status Line Indicators

The bottom line of the graphics LCD display is used to indicate the status of the display and of the recorder itself. These status icons consist of reverse video characters or letters that appear according to operations performed and are intended to prevent data on the display from being misinterpreted and to indicate the status of the alarms.

**1 2 3 4 X ↔ HF**

From left to right these icons are as follows:

**1 2 3 4** - These icon symbols indicate that the alarms are enabled (1 is Alarm 1 etc.). Any number of them may be present depending on how the alarms have been set up. If an alarm is enabled a solid block will be present. If the alarm has exceeded the setpoint (i.e. is in an alarm condition) its symbol will be **blinking**.

**X** - This symbol indicates that the external input is enabled. If the external input is triggered this symbol will blink.

**↔** - This symbol indicates the display is in the **COMPRESSED** mode. The amount of compression can be determined from the time date stamps on the display. To exit from the Compressed Mode simply press the **MENU** button.

**H** - This symbol indicates the display is in the **HOLD** mode. The displayed data is no longer real time and will not be updated. The Hold mode is entered by pressing either the **LEFT** or **RIGHT** arrow button, entering the compressed mode, or viewing any internally buffered data.

**F** - This symbol indicates the data on the display is from a **FILE** on the **MEMORY CARD** and not current data. To view data from a file, use the **MENU** selection option "VIEW FILE". Note that if currently recording, viewing a file does not disrupt the recording procedure provided that the file you are viewing is on the same memory card as the one you are recording on *OR* you do not exceed the buffer storage time on the recorder if you are using another memory card.

### 3.8 Entering Data

When adjusting or entering values you have to use the ▼ ▲ ▶ ◀ button keys.

**Alphanumeric Values** – The ▶ key moves the cursor to the right to select the character to be edited. It will wrap around from right to left. The ▼ ▲ change the character as shown in Appendix A. The **MENU** button accepts the data and exits and the ◀ key escapes.

**Numeric Values** – work a little differently; the value increments and decrements according to the up ▲ or ▼ down keys. Single presses increment or decrement the value by 1. If the button is pressed and held down the value will increment or decrement in steps of 10. If the **MENU** button is held down and the ▲ or ▼ button is pressed and held down, the value increments or decrements by 100. The **MENU** button accepts the data and exits and the ◀ key escapes.

This space intentionally left blank.

### 3.9 Top Level Menu Overview

| Top Level    | Level 1                     | Function   |
|--------------|-----------------------------|--|
| EXIT         |                             | Exits from Menu  |
| ALARM RESET  |                             | Resets any Alarms. Note if Alarm is still active it will set again. Auto exits menu  |
| RECORD MODE  |                             | Enter Password (if set) then press MENU.   |
|              | OFF                         | Stop Recording   |
|              | ON                          | Start Recording  |
|              | TRIGGERED                   | Arm Triggered Recording. An External Event will start and stop recording as programmed.  |
|              | NAME FILE                   | Enter the name for recorded files up to 8 Characters. Use ▼▲► keys.<br>◀ key to escape, clear or list directory<br>Use MENU key to Save and Exit   |
|              | SAVE CONFIG                 | Save Configuration<br>Enter Config File Name - up to 8 Characters.<br>Use ▼▲► keys.<br>◀ key to escape, clear or list directory.<br>Press MENU to save and exit  |
|              | LOAD CONFIG                 | Load Configuration.<br>Enter Config File Name - up to 8 Characters.<br>Use ▼▲► keys.<br>◀ key to escape, clear or list directory.<br>Press MENU to save and exit<br>Unit will restart on successful load |
| CURSOR ID    |                             | Puts chart in HOLD mode and places cursor on screen.<br>Use ◀► keys to move cursor and read trend values at top.<br>Press MENU key to exit this mode.  |
| VIEW FILE    |                             | Select an existing file on the CARD to browse.<br>Enter File Name - up to 8 Characters.<br>Use ▼▲► keys.<br>◀ key to escape, clear or list directory.<br>Press MENU to browse.                           |
| CARD STATUS  |                             | Pops up window show memory card status. Includes capacity, % full, time remaining. Select again to remove window.  |
| SAMPLE RATE  |                             | Enter Password (if set) then press MENU.   |
|              | 100 S/sec<br>to<br>10 sec/S | Select sample rate from 100 Samples/sec to 10 min/Sample.<br>Use ▼▲ keys to navigate<br>◀ key to escape without change.<br>Use MENU key to select and exit   |
| PASSWORD     |                             | Enter Password using ▼▲◀► then press MENU<br>Repeat at prompt, press MENU to select and exit   |
| ADV. SETUP   |                             | Enter Password (if set) then press MENU.<br><b>See Section 4</b>   |
| DISPLAY ADJ. |                             | Adjust Viewing angle (VIEW) ◀► and<br>Back Light (BKLT) ▲▼. Press MENU to exit.  |

## 4.0 ADVANCED SETUP

The ADVANCED SETUP menu may be password protected. This menu is used to program the various operating parameters of the recorder. This includes analog inputs, alarms, display settings, the clock and various trigger modes.

All items on this menu have one or more sub-menus. To locate the Advanced Setup menu, press the **MENU** button from any normal view mode. The Advanced Setup menu will not be visible when the menu first appears. Use the Up Arrow (▲) and Down Arrow (▼) buttons to scroll and highlight **ADV. SETUP** and press the **MENU** button. This will bring up the Advanced Setup menu shown on the left. Current settings in sub menus are indicated by a ✓ (check mark) along side the item or by the item being highlighted. See above for details on entering data.

**CHAN A SETUP..**  
**CHAN B SETUP..**  
**ALARMS..**  
**RELAYS..**  
**DISPLAY..**  
**DATA CARD..**  
**CLOCK..**  
**BEEPER..**  
**SAMPLE TRIG..**  
**REC. TRIG..**  
**EXT. INPUT..**  
**UNIT TAG..**  
**COMMS..**

### 4.1 Channel Setup

This menu option enables the user to program the inputs of the recorder. Each channel can be set up as an analog input – volts, currents, thermocouple or RTDs, or as digital inputs from RPM or frequency measurements. There is no need to swap out modules since the inputs are universal. Filtering may be applied to each channel for stability of readings or to catch peak values if the display rate is slower than the sample rate. (The unit always samples at 100 samples per second per channel. For increased accuracy each range may be calibrated independently. Use the Up Arrow (▲) and Down Arrow (▼) buttons to scroll and highlight **CHAN n SETUP** (n = A or B) and press the **MENU** button. The menu options are shown expanded below.

| INPUT TYPE   |                        | Note: Menu will differ depending on Input Type selection   |
|--------------|------------------------|--|
| VOLTS        | 250mV to 25.0Vdc       | Select full scale input Voltage<br>Input is for DC Volts   |
| mA           | 4-20 mA to 0 - 50mAdc  | Select full scale input Current. Input is for DC milliAmps. External Shunt of 250 Ohms is required.                              |
| THERMOCOUPLE | J, K, K(hi)T, E        | Select required Thermocouple (T/C) type  |
| RTDs         | Pt385 or 392           | Select required RTD Type   |
| FREQUENCY    | 100 Hz to 10kHz        | Select Frequency for Full Scale Range  |
| SPEED        | 100 RPM to 600,000 RPM | Select Speed for Full Scale Range  |
| OFF          |                        | Turns Channel OFF (toggles) ✓=OFF  |
| LO SCALE     |                        | Default value is low end of range.<br>For Offset. Use ▼▲► keys to adjust<br>◀ key escapes, <b>MENU</b> key to Save and Exit      |
| HI SCALE     |                        | Default Value is top end of range.<br>For Full Scale. Use ▼▲► keys to adjust.<br>◀ key escapes, <b>MENU</b> key to Save and Exit |

|                    |                |   |
|--------------------|----------------|---|
| <b>CHAN TAG</b>    |                | Enter a Channel Tag Identifier up to 5 Characters. Use ▼▲► keys. ◀ to clear or escape. Use MENU key to Save and Exit  |
| <b>CHAN UNITS</b>  |                | Default value is Range value<br>Enter a Channel Units. Some Ranges have defaults. Enter up to 3 Characters. Use ▼▲► keys. ◀ to clear or escape. Use MENU key to Save and Exit |
| <b>FILTER</b>      |                | Note: Unit always samples at 100 samples/sec internally   |
|                    | NORMAL         | No filtering  |
|                    | AVERAGE        | Display shows AVERAGE over last sample interval   |
|                    | HI PEAK        | Display shows HI PEAK (max) values over last sample interval  |
|                    | LO PEAK        | Display shows LO PEAK (min) values over last sample interval  |
|                    | FAST FILT      | Averages last 10 samples continuously<br>Choice is:<br>NEITHER<br>CHAN A<br>CHAN B<br>BOTH  |
| <b>CALIBRATION</b> |                |   |
|                    | CAL ZERO       | (If applicable) - Input zero and adjust ▼▲► for zero. MENU to accept.   |
|                    | CAL SPAN       | Input Max Span value and adjust ▼▲► for correct value. MENU to accept.  |
|                    | CAL NOMIN.     | Copies default calibration value to this range  |
|                    | CAL NOMIN. ALL | Copies default value to all ranges  |

## 4.2 Alarms

This option is used to program the alarms. There are four alarms and each is programmed independently. Each alarm may be turned on or off and may be assigned to either channel.

Use the Up Arrow (▲) or Down Arrow (▼) buttons to scroll and highlight **ALARMS..** and press the **MENU** button. The menu options are shown expanded below.

|                              |   |
|------------------------------|---|
| <b>ALARM n</b> (n = 1,2,3,4) |   |
| ENABLE                       | Turn Alarm n on or off - <input checked="" type="checkbox"/> ENABLED is on              |
| HIGH                         | Select if ALARM is HIGH   |
| SETPOINT                     | Set ALARM Trip point. Use ▼▲► keys to adjust ◀ to escape, MENU key to Save and Exit     |
| DEADBAND                     | Set ALARM DeadBand point. Use ▼▲► keys to adjust ◀ to escape, MENU key to Save and Exit |
| CHAN A                       | Select CHAN A as Source for Alarm   |
| CHAN B                       | Select CHAN B as Source for Alarm   |
| LOW                          | Same as HIGH<br>Select if ALARM is LOW  |



|             |   |
|-------------|---|
| HOLD OFF    | Use ▼▲ keys to enter time in seconds from Alarm till relays pull in.      |
| RESET DELAY | Use ▼▲ keys to enter time in seconds from RESET till relays drop out.     |
| LATCHING    | Toggle using <b>MENU</b> - make alarm latching                            |
| LOCK OUT    | Prevents a low alarm activating until the setpoint has been exceeded once |
| DEFAULT     |   |

### 4.3 Relays

This option is used to program the physical relay outputs. There are two relays and each is programmed independently. The relays can be assigned to one or more ALARM events or the EXTERNAL INPUT. Use the Up Arrow (▲) or Down Arrow (▼) buttons to scroll and highlight **RELAYS..** and press the **MENU** button. The menu options are shown below.

|   |                                  |
|---|----------------------------------|
| <b>RELAY 1</b>  |                                  |
| OFF   | RELAY is OFF                     |
| ALARM 1   | RELAY is tied to ALARM 1         |
| ALARM 2   | RELAY is tied to ALARM 2         |
| ALARM 3   | RELAY is tied to ALARM 3         |
| ALARM 4   | RELAY is tied to ALARM 4         |
| EXT INPUT   | Relay is tied to EXTERNAL INPUT  |
| <b>RELAY 2</b>  | same as RELAY 1                  |
| <b>FAILSAFE</b> Relays are energized in the non alarm condition |                                  |
| NEITHER   | Select Neither relay as failsafe |
| RELAY1  | Select RELAY 1 as failsafe       |
| RELAY2  | Select RELAY 2 as failsafe       |
| BOTH  | Select both relays as fail safe  |

### 4.4 Display

This option is used to set up the display. The Window Configuration allows the user to choose how to display data - either as a trend or as digital values or as a combination of both. The time stamp that appears on the trend can be customized, the menu can be set to disappear and have the display revert back to normal, and the backlight can be set to go off after a period of inactivity. (The backlight will restore on any event.) Use the Up Arrow (▲) or Down Arrow (▼) buttons to scroll and highlight **DISPLAY..** and press the **MENU** button. The menu options are shown below.

|                      |  |
|----------------------|--|
| <b>WINDOW CONFIG</b> |  |
| TREND                | Set display to full screen TREND (both Channels)               |
| DUAL DIGITAL         | Set display to DUAL DIGITAL readouts                           |
| BOTTOM DIGITAL       | Set display to TREND in top half, DIGITAL in lower half (CH B) |
| INV DIGITAL          | Set DIGITAL display to WHITE characters on DARK background.    |
| ALARM BLINK          | DIGITAL value will blink when in alarm                         |
| DIGITAL <-->         | SWAP the position of dual digital windows.                     |

|   |   |
|---|---|
| <b>TIME STAMP</b>   |   |
| NONE  | No imprint of TIME or DATE on TREND display   |
| TIME ONLY   | TIME imprints on TREND display  |
| TIME & DATE   | TIME and DATE imprint on TREND display  |
| TOP   | Set location of Time (& Date) imprint to TOP of TREND                                       |
| MIDDLE  | Set location of Time (& Date) imprint to MIDDLE of TREND                                    |
| BOTTOM  | Set location of Time (& Date) imprint to BOTTOM of TREND                                    |
| <b>MENU TIMEOUT</b>   |   |
| NEVER   | MENU will never Collape (and revert to display mode)  |
| 30 SEC to 30 MINUTES  | Choose MENU TIMEOUT from 30 seconds to 30 Minutes. Menu will revert back to normal display. |
| <b>BACKLIGHT</b>  |   |
| LIGHT TIMEOUT   |   |
| NEVER   | BackLight will never shut off   |
| 30 SEC to 30 MINUTES  | Choose time to backlight shut off from 30 seconds to 30 Minutes after inactivity.           |
| BATTERY OFF   | Select to turn back light off in battery mode to save power. (battery is optional)          |
| <b>PEN TYPE</b>   |   |
| CHAN A ---  |   |
| SOLID   | Set CHAN A TREND line to SOLID _____  |
| DOT   | Set TREND line to a series of DOTS .....  |
| DASH  | Set TREND line to a series of DASHES - - - -  |
| DOT-DASH  | Set TREND line to a series of DOTS and DASHES   |
| CHAN B - --   |   |
| Set CHAN B TREND lines as above   |   |
| <b>DISPLAY ADJ.</b> Same as Top Level Menu option (see <a href="#">3.5.10</a> ) |   |

#### 4.5 Data Card

This option contains duplicate menu items to those found in the RECORD MODE menu. In addition it enables the user to test the card and format it for use (recommended). Use the Up Arrow (▲) or Down Arrow (▼) buttons to scroll and highlight **DATA CARD..** and press the **MENU** button. The menu options are shown below.

|                    |   |
|--------------------|---|
| <b>NAME FILE</b>   | Enter the name for recorded files up to 8 Characters. Use ▼▲► keys.<br>◀ key to escape<br>Use <b>MENU</b> key to Save and Exit                                  |
| <b>SAVE CONFIG</b> | Save Configuration<br>Enter Config File Name - up to 8 Characters.<br>Use ▼▲► keys.<br>◀ key to escape. Press <b>MENU</b> to save and exit                      |
| <b>LOAD CONFIG</b> | Load Configuration. Unit will show list of files.<br>Use ▼▲ to select, ◀ key to escape. <b>MENU</b> to select and load.<br>Unit will restart on successful load |
| <b>TEST CARD</b>   | This is a non-destructive test to check the card.   |

|                    |  |
|--------------------|--|
| <b>ERASE CARD</b>  | Erase File. Unit will show list of files on card<br>Use ▼▲ to select, ◀ key to escape. MENU to select and erase. |
| <b>FORMAT CARD</b> | This will FORMAT the card for use in the recorder.<br><b>ALL DATA WILL BE DESTROYED</b>                          |

#### 4.6 Clock

This option allows the user to set the time and date and determine what is displayed for time on the bottom right of the display. Use the Up Arrow (▲) or Down Arrow (▼) buttons to scroll and highlight **CLOCK..** and press the **MENU** button. The menu options are shown below.

|                 |   |
|-----------------|---|
| <b>MODES</b>    |   |
| TIME OF DAY     | Select Time Display as Real Time Clock  |
| 24 HR           | Select Time Display as 24 hour or 12 hour AM/PM   |
| AUTO DST        | Select to enable Daylight Saving Time adjust  |
| TIME ZONE       | Allow for international time correction. Actual time recorded is GMT. This corrects for current local time so data is global. |
| MM/DD/YY        | Select date format as Month/Day/Year  |
| DD/MM/YY        | Select Date format as Day/Month/Year  |
| SAMPLE TIME     | Show time of actual last sample   |
| DEFAULT         | Select default setup: Time of Day, 12 hour format , DST on, Date format is MM/DD/YY   |
| <b>SET TIME</b> | Set Time ◀▶ Adjusts hours. ▲▼ adjusts minutes, <b>MENU</b> accepts  |
| <b>SET DATE</b> | Set Date ◀▶ Adjust month/year. ▲▼ adjusts days. <b>MENU</b> accepts   |

#### 4.7 Beeper

This option allows the user to have various events sound the beeper, Alarms, message boxes and key presses. The tone of the beeper may also be programmed. Use the Up Arrow (▲) or Down Arrow (▼) buttons to scroll and highlight **BEEPER..** and press the **MENU** button. The menu options are shown below.

|                   |  |
|-------------------|--|
| <b>ALARMS</b>     |  |
| OFF               | BEEP on ALARMS turned off if checked                   |
| ALARM 1           | Beep on Alarm 1  |
| ALARM 2           | Beep on Alarm 2  |
| ALARM 3           | Beep on Alarm 3  |
| ALARM 4           | Beep on Alarm 4  |
| EXT INPUT         | Beep on External Input                                 |
| <b>ALARM TONE</b> | Not selected is a continuous high tone                 |
| TONE A            | Select Alarm TONE A - add warbling effect              |
| TONE B            | Select Alarm TONE B - add short silence between tones  |
| TONE C            | Select Alarm TONE C - add longer silence between tones |
| TONE D            | Select Alarm TONE D - add long silence between tones   |
| <b>MSG BOXES</b>  | BEEP on POP-UP MESSAGE BOXES active if checked         |
| <b>BUTTONS</b>    | BEEP on BUTTON PRESS active if checked                 |

#### 4.8 Sample Trigger

This option allows the user to program what will trigger a change of sample rate in the displayed or recorded data. Use the Up Arrow (▲) or Down Arrow (▼) buttons to scroll and highlight **SAMPLE TRIG..** and press the **MENU** button. The menu options are shown below.

- ⇒ Note that if an event is selected to change the sample rate, when exiting the menu the sample rate menu will be displayed. Use the Up Arrow (▲) or Down Arrow (▼) buttons to scroll and highlight the new sample speed and press the MENU button to select and the Left Arrow (◀) button to exit.

|                  |                                      |
|------------------|--------------------------------------|
| <b>OFF</b>       | No Sample Rate change if checked     |
| <b>ALARM 1</b>   | Sample Rate change on Alarm 1        |
| <b>ALARM 2</b>   | Sample Rate change on Alarm 2        |
| <b>ALARM 3</b>   | Sample Rate change on Alarm 3        |
| <b>ALARM 4</b>   | Sample Rate change on Alarm 4        |
| <b>EXT INPUT</b> | Sample Rate change on External Input |

#### 4.9 Record Trigger

This option allows the user to choose an event to start the recording. Use the Up Arrow (▲) or Down Arrow (▼) buttons to scroll and highlight **REC. TRIG..** and press the **MENU** button. Select either **OFF**, **ALARM 1** through **4** or **EXTERNAL INPUT** as the record trigger.

- ⇒ Note that if an alarm reset delay is set (see Section 4.2), the unit will continue to record for this time period **AFTER** the alarm has gone away.

#### 4.10 External Input

This option allows the user to program the external digital input. This needs to be programmed before it can be used for event triggering if programmed above. Use the Up Arrow (▲) or Down Arrow (▼) buttons to scroll and highlight **EXT. INPUT..** and press the **MENU** button. The menu options are shown below.

|                    |   |
|--------------------|---|
| <b>ENABLE</b>      | Enable External Input   |
| <b>HIGH</b>        | External Sense is HIGH to register. (> 5V)  |
| <b>LOW</b>         | External Sense is LOW to register (=0V)   |
| <b>HOLD OFF</b>    | Time in seconds from EXT input present till recognized  |
| <b>RESET DELAY</b> | Time in seconds from EXT input absent till recognized   |
| <b>LATCHING</b>    | Once set, will remain set till the RESET option is pressed  |
| <b>LOCK OUT</b>    | External Input requires a change of state in order to be recognized. For a High condition on startup or reset, if the input is high at that time it needs to go low first, then high in order to be recognized. |
| <b>DEFAULT</b>     | Set Defaults - Disabled, High level, all else set to zero   |

#### 4.11 Unit Tag

The unit tag is used to identify the recorder. It is saved to the data file when recording and can be read back by the analyzing software. It is also displayed on the top of the main menu when the MENU button is pressed for the first time. It can be a maximum of 15 characters. Select this option then use the ▼▲► keys to adjust and the ◀ key to escape or the **MENU** key to Save and Exit. See Entering Data above for details.

#### 4.12 Comms

This option allows the user to set the IP Address and Subnet Gateway for the Ethernet Option. Use the .key to select the digit to change (Indicated by [123]) and ▼▲ to change it. Use the **MENU** to accept or ◀ to escape.

## 5.0 MISCELLANEOUS

### 5.1 Battery Backup Option

If the recorder contains the Battery Backup Option, there is a toggle switch on the back panel below the terminal block. The switch is marked ON and OFF.

In the OFF position, the battery is disconnected from the load and the recorder is off. The battery charges with the switch OFF when the recorder is plugged into AC power.

In the ON position, with external power applied, the unit runs normally and automatically switches to battery backup in the event of a power failure. The recorder continues to run from the battery until power is restored. If the battery voltage reaches a preset low voltage threshold, the battery is automatically disconnected and the recorder shuts off. When external power is restored, the unit starts up normally and the batteries begin to recharge. Likewise, the unit can run off internal battery without external power by simply turning the unit ON. The recorder switch should be turned OFF when not in use.

Additionally there is a procedure to turn the backlight off when the unit is running on battery. See Section 4.4. This action extends the battery life and the unit continues to operate normally. The green power LED on the front panel will blink when the recorder is being powered from the battery. Run times vary from 8 to more than 12 hours depending on load conditions. It takes 10 to 14 hours for the battery to fully charge.

### 5.2 Ethernet Option

The Ethernet option is field installable and can be added to the recorder at any time PROVIDED there is no USB option installed. **The Ethernet and USB options are mutually exclusive.** See Field Installation Instructions (Part No. 1071-1256-110R) to add the Ethernet card to the recorder. If the product was ordered with the Ethernet option, it will have been factory installed.

#### Setting the IP Address

The recorder needs to have the IP address set manually by the user. The address should be set so it is compatible with the environment into which it connects.

To set the IP address:

Select MENU.

Using the ▲ ▼ buttons select **ADV SETUP** then **COMMS**.

Select IP ADDRESS then use the ▲ ▼▶◀ keys to set an address. (▶◀ selects which group of digits to adjust then ▲ ▼ changes the number.) To accept the address, press the **MENU** button.

The IP address you set depends on how you plan to access the device. If you have a local connection, the IP address needs to match the setting on your computer. The address will be in the form 192.168.0.210. Check your computer's IP Address then set the recorder address so that the first three sets of numbers match that of your computer. The last digit should be different and should be unique – check with your IT department if you are unsure.

Select **SUBNET MASK** and set it to 255.255.255.0, which is typical, or to whatever your system requires and then press the **MENU** key. Use the ◀ key to exit the menu.

Connect the Ethernet cable to the recorder. There are two LEDs on the connector – one indicates connection, the other indicates activity. Note that you cannot connect the recorder directly to your computer - you need to have a hub or switch.

The connection can be tested by using the DOS Command Box and pinging the units. At the DOS prompt type: Ping 192.168.0.210 (use the IP address you set).

If the connection is good you will see a series of replies from the recorder. If you cannot connect, try pinging the address with the recorder disconnected from the Ethernet. If you get a reply there is another device with that IP address. Change the IP address on the recorder.

There are two methods of connecting to the recorder over the Ethernet – Browser connection and Navigator Software.

### Browser connection

Launch your browser (Internet Explorer preferred – V6 or later).

You need to ENABLE ACTIVE X and JAVASCRIPT. (From the browser toolbar, select TOOLS then INTERNET OPTIONS then SECURITY. Select CUSTOM LEVEL and choose MEDIUM LOW or adjust the settings manually).

Enter the Recorder IP address into your browser and click GO. You should see a picture of the Recorder and the data should update at a 3 to 5 second update rate depending on Ethernet traffic and recorder chart speed (slower chart speeds will result in faster updates over the Ethernet.) Note that the browser shows the recorder status in real time.

### Navigator Software

The Navigator software enables the user to fully interact with the recorder over the Ethernet. You can alter settings, stop and start recording, download data in real time for plotting or archiving on the PC, and you can download historic data files.

Refer to the Navigator Software manual for additional information.

## 5.3 Calibration

Before leaving the factory, the recorder is calibrated using NIST traceable sources. The calibration values are stored in non-volatile memory. The unit is calibrated to meet specification but the user may wish to re-calibrate the unit, or calibrate specific input ranges for increased accuracy.

Calibration is the process of “fine tuning” each input for various differences that may arise due to manufacturing processes, gain errors, temperature offsets and other physical parameters. Real analog to digital (A/D) converter values are corrected by first adding an offset correction value, nominally zero, to the reading to correct for offsets from zero, and then multiplying it by a span correction value that's nominally 1 to correct for gain errors.

Calibration setup can be found in the **Channel x Setup Menu** (x = A or B) under the ADVANCED SETUP menu options. Each channel needs to be calibrated independently.

There are four options on the calibration menu:

- |                    |  |
|--------------------|--|
| <b>CAL ZERO</b>    | adjusts the offset correction above or below actual 0 (zero), in steps equal to the resolution of the A/D converter itself.  |
| <b>SPAN</b>        | adjust a span correction value above or below actual 1, also in small amounts.   |
| <b>NOMINAL</b>     | depending on the input range selected, either resets the correction values to 0 and 1, or copies those values from the range it's a derived from. This usually affects only the input type category selected for the current channel.                    |
| <b>NOMINAL ALL</b> | will reset all correction values for all input types on both channels when selected from any input type and channel, a sort of master reset. This is the default in the event that calibration data is found to be corrupted in the non-volatile memory. |

### 5.3.1 Basic Calibration

All calibration values are derived from a couple of key calibration points. Thereafter, any fine-tuning done to a specific input on a channel is saved for that channel and input range only. The key calibration constants are for:

|                |  |
|----------------|--|
| Lo Volts       | covering the 250mV, 1.25V, 2.50V ranges and should be done on the 250mV range – each channel   |
| Hi Volts       | covering the 5.00V, 12.5V, 25.0V ranges and should be done on the 5.00V range – each channel   |
| THERMOCOUPLES  | which are derived from the Lo Volts calibration value require an additional offset to compensate for the ambient temperature sensor – each channel                   |
| RTDs           | which are derived from Lo Volts calibration value require an additional span calibration to correct for the internal current source – each channel                   |
| CURRENTS       | which are derived from the Hi Volts calibration value require an additional span calibration to correct for the external resistor (Customer supplied) – each channel |
| FREQ and SPEED | requires only a time base calibration shared for both channels   |

In general, to calibrate an analog input, first set the specific channel to an input type in the ADVANCED SETUP MENU - CHANNEL SETUP - INPUT TYPE (see Section 4.1). Once an input type has been chosen, select CALIBRATION (see Section 4.1). Do not change the units from the default values set when that range is selected (i.e. leave volts as volts and current as current).

Apply a "zero" value to the input and using the up (▲) and down (▼) arrow buttons adjust the OFFSET until the onscreen indications shows zero.

Apply a "high" value to the same input and using the up (▲) and down (▼) arrow buttons adjust the SPAN until the onscreen indication agrees with the input (Note – use an input value slightly less than the full scale value to prevent an overrange indication).

Repeat for all input types and channels to be used, if not all of them.

### 5.3.2 Examples

**Volts:** Should be done for the Lo Volts - 250mV, 1.25V, 2.50V ranges, and Hi Volts - 5.00V, 12.5V, 25.0V ranges using the 250mV and 5.00 volt ranges respectively. For each channel individually, set the input for 250mV and go to Calibration. Short the input and adjust the OFFSET until 0 is indicated. Then apply a near full scale input (so as to not over range the input, say 240 mV on the 250 mV range) and adjust the SPAN.

**Thermocouples:** (preferred method) First calibrate lo VOLTS range (250mV) for the same channel as described above. Then switch to Thermocouple range. Select NOMINAL to copy the volts calibration to thermocouple range. The recorder is now calibrated for ideal sensors. Refine the calibration by either shorting the input (you need to know the ambient temperature) or attaching a thermocouple sensor or calibrator of the correct type for the selected range, and then if necessary, adjust the OFFSET until the correct temperature is displayed – this corrects the ambient temperature sensor. If there's a known "high" temperature source handy use that to fine-tune the SPAN value.

**Currents:** (preferred method) First calibrate Hi VOLTS range (5.00V) for the same channel as described above. Then switch to any CURRENT range. Select NOMINAL to copy the volts calibration to the current range. The recorder is now calibrated for ideal resistor (250 ohm). Refine calibration for resistor and sensor current tolerances by attaching a 250 ohm +0.1% resistor and input sensor matching the selected range. Apply low value inputs to adjust the OFFSET value, and high value inputs to adjust the SPAN value.

**RTDs:** (preferred method) First calibrate lo VOLTS range (250mV) for the same channel as described above. Then switch to RTD range. Select NOMINAL to copy the volts calibration to RTD range. The recorder is now calibrated for ideal sensors and internal current source. Refine the calibration by applying an accurately known resistance for a given temperature (you may need resistance to RTD tables). Adjust the SPAN until the correct temperature is displayed – this corrects for the internal current source.

**Frequency (RPM or Hz):** Apply a calibrated frequency input near the high end of the selected input range of either channel. Adjust SPAN until the indicated value is correct. There is no applicable OFFSET adjustment to be made.

Recommended procedure for full initial calibration, in this order:

- Calibrate 250 mV range, both channels using a calibrated source.

- Calibrate 5.00 V range, both channels using a calibrated source
- Calibrate any T/C range, both channels using the NOMINAL method.
- Calibrate any RTD range, both channels using NOMINAL method
- Calibrate any current range, both channels using NOMINAL method
- Calibrate any Tach range, either channel using a calibrated signal source.

**NOTES:**

As with other numeric editing, the rate that a calibration value is adjusted accelerates with the length of time the button is pressed.

Calibrating either channel for tachometry calibrates both channels and does not have to be repeated for each channel as they use the same base counter. Additionally there's no OFFSET adjustment for these inputs.

Thermocouple and RTD linearization tables are very accurate; usually calibrating the 250mV range for the same channel and then copying the calibration values using NOMINAL should be enough. Remaining sources of error are the ambient sensor (probably small) for the thermocouple and the current source (small) for the RTD, and the actual sensors themselves. The ambient sensor can be calibrated by adjusting the OFFSET with the thermocouple at some known temperature (such as ice water) or a known room temperature with a wire short on the input. The input sensor span adjustment would need a high temperature point to calibrate.

There can be interaction between the OFFSET and SPAN with the thermocouple input since it can't be easily determined when exactly 0 volts is applied in combination from the ambient and input sensors. This can happen with other input types where the input used for the OFFSET adjustment does not present 0 volts to the input.

Calibration values are copied to an EEPROM (non volatile) device when performing the calibration operations. These values are copied from the EEPROM upon every power up of the recorder and tested for corruption. If the values are found in error then nominal values are inserted in all categories.

**5.4 Specifications**

|                            |  |
|----------------------------|--|
| <b>Input Power:</b>        | Recorder: 9Vdc +0.5V @ 5VA (depends on external loads)<br>External AC Universal adaptor: 100 – 240Vac 50/60 Hz<br>Optional isolated: 12 – 24 Vdc input (not compatible with Battery Backup Option)   |
| <b>Battery Option:</b>     | Internal battery pack provides uninterrupted operation during black out. 6Vdc 2400 mAH NiMH – backup time 6 hours typical – depends on external load.  |
| <b>Output:</b>             | 2 outputs 5Vdc @ 50mA to power external sensors<br>Isolation – 300V DC/AC to system ground/chassis.  |
| <b>No of Channels:</b>     | 2  |
| <b>Universal DC Input:</b> | Isolated input: 300V AC/DC to system ground/chassis. Inputs share a common ground connection.  |
| <b>DC Input:</b>           | Resolution: 0.025%   |
| <b>Voltage:</b>            | Ranges: 0 to 250mV; 1.25V; 2.5V; 5V; 2.5V; 25V<br>Accuracy 0.1%.   |
| <b>Current:</b>            | Accuracy: 0.1% excluding 250 ohm external shunt (required)<br>Ranges: 0 – 20mA; 4 – 20mA; 0 – 50mA; 10 – 50mA  |
| <b>Thermocouple:</b>       | Accuracy: 0.3%. Ambient temp. sensor accuracy +1.5°<br>J -100 to 760 °C +2°C (-148 to 1400 °F +3°F)<br>K -100 to 1000°C +2°C (-148 to 1830 °F +3°F)<br>T -100 to 400 °C +2°C (-148 to 750 °F +3°F)<br>E -80 to 400 °C +2°C (-112 to 750 °F +3°F) |



|   |   |
|---|---|
| <b>RTD:</b>   | 2 or 3 wire. Resolution 0.1°C, Accuracy 0.3%<br>Internal current source: 1mA<br>100 ohm Pt385            -100 to 750°C (-148 to 1380 °F)<br>100 ohm Pt 392           -100 to 750°C (-148 to 1380 °F)  |
| <b>Frequency Input (Hz)/<br/>Speed Input (RPM):</b> | Range:            0 – 10,000 Hz or 0 – 600,000 RPM<br>Accuracy:        Freq: ±1Hz;<br>RPM: ±1 RPM to 9,999 RPM then ±10RPM<br>Input: low: <1.0Vdc    high: >3.0Vdc <12Vdc<br>Pulse width: 10µsec minimum  |
| <b>Input Impedance:</b>                             | >100k   |
| <b>Measurement Rate:</b>                            | up to 100 samples/sec per channel   |
| <b>Math Function:</b>                               | y = mx + b; average, hi peak., lo peak  |
| <b>Media:</b>                                       | Compact Flash to 2 GB   |
| <b>Display:</b>                                     | LCD Graphics 160 x 80 pixels black FSTN with White LED backlight<br>User controlled Backlight level and Contrast adjust (electronic)  |
| <b>Display Modes:</b>                               | Trending (Horizontal), Large Dual Digital Readout, Mixed Mode   |
| <b>User Interface:</b>                              | 5 buttons keypad with 2nd Function operation  |
| <b>Clock:</b>                                       | Internal battery backed clock, with auto leap year and daylight savings   |
| <b>Relay Output:</b>                                | Two alarm outputs: 30V 0.5A Form A relays   |
| <b>Opto-isolated Input:</b>                         | One input 5 to 12Vdc operation @ 10mA typical.  |
| <b>Audible:</b>                                     | Internal buzzer (tones)   |
| <b>Dimensions:</b>                                  | Front panel 96mm x 96mm (1/4 DIN) x 152mm (3.78 x 3.78 x 6 inches).   |
| <b>Environmental:</b>                               | <b>Indoor Use Only</b><br><b>Installation Category II</b> per IEC 664<br><b>Pollution Degree Level II</b> per IEC61010-1<br><b>Altitude</b> up to 2,000 m<br><b>Temperature</b> -10 °C to 50 °C operating per IEC61010-1<br><b>Humidity</b> Maximum relative humidity 80% for temperatures up to 31 °C decreasing linearly to 50% relative humidity at 40 °C. |
| <b>Certification:</b>                               | CE – EN61326 EMI/EMC            EN61010-1 Safety<br>UL and cUL (Power Supply)   |
| <b><u>Optional Communications</u></b>               |   |
| <b>USB</b>  | Front panel USB 2.0 slave port for data transfer and configuration.   |
| <b>Ethernet</b>                                     | 10/100 Ethernet   |

This space intentionally left blank.

## APPENDIX A - UNITS LABEL CHARACTERS

The following is a list of the characters are available any place text can be entered. The list will start with the A character (underlined) and the UP and DOWN arrows move through the list in order left to right. The characters in shadow are NOT legal for file names.

|         |          |   |   |    |   |   |   |
|---------|----------|---|---|----|---|---|---|
| (space) | !        | " | # | \$ | % | & | ' |
| (       | )        | * | + | ,  | - | . | / |
| 0       | 1        | 2 | 3 | 4  | 5 | 6 | 7 |
| 8       | 9        | : | ; | <  | = | > | ? |
| @       | <u>A</u> | B | C | D  | E | F | G |
| H       | I        | J | K | L  | M | N | O |
| P       | Q        | R | S | T  | U | V | W |
| X       | Y        | Z | [ | \  | ] | ^ | _ |
| `       | a        | b | c | d  | e | f | g |
| h       | i        | j | k | l  | m | n | o |
| p       | q        | r | s | t  | u | v | w |
| x       | y        | z | { |    | } | ~ | # |
| ↑       | ↓        | ® | ¬ | °  | µ | Ω |   |

## APPENDIX B - ERROR AND INFORMATION MESSAGES

The following messages appear on the Graphics screen as a result of the following: (*suggested solutions appear in italics*)

|  |  |
|--|--|
| <b>ACCESS DENIED</b>                           | An incorrect password was entered while attempting to gain access to a password protected function. <i>Find someone who has the right password.</i>  |
| <b>BAD FILENAME</b>                            | The filename entered does not meet the DOS requirement. Use A to Z and 0 to 9 without spaces, 8 characters max. <i>Re-enter the name.</i>  |
| <b>CARD ABSENT</b>                             | Failed attempt to read from (viewing) or write to (recording) a memory card which is not present. <i>Insert a card.</i>  |
| <b>CARD ACCESS ERROR</b>                       | Failed attempt to read or write a memory card due to file data corruption. <i>Format and erase card - data will be lost.</i>   |
| <b>CARD FULL</b>                               | Failed attempt to write to a memory card which is filled to capacity. <i>Exchange card with a new one that has spare capacity.</i>   |
| <b>ENTER CURRENT PASSWORD ENTRIES MISMATCH</b> | You have attempted to access a password protected function and must enter the password to continue. <i>Enter current password.</i>   |
| <b>ENTRY ERROR</b>                             | This time password did not match last time password when setting up. <i>Try it again, only more slowly.</i>  |
| <b>ENTRY ERROR</b>                             | An illegal number of keystrokes were entered while entering the password. <i>Try it again, only more slowly.</i>   |
| <b>FILE NOT FOUND</b>                          | Failed attempt to read a data file or configuration file due to the fact that no such file exists on the memory card. <i>Get the correct card.</i>   |
| <b>FORMAT CARD OVERWRITE CONFIG. FILE?</b>     | Card is incompatible or unformatted. Requires formatting. A config file already exists on the memory card. Writing to the card will overwrite this existing file. The unit is checking user intent. <i>Press the UP ARROW key to overwrite the existing file, any other key to exit.</i> |
| <b>STOP RECORDING FIRST TEST FAIL</b>          | The function you are trying to perform cannot be done while the unit is in record mode. <i>Stop recording and try again.</i><br>The card has errors on it and did not pass the card test. <i>Try reformatting the card or swap the card.</i>   |

## APPENDIX C - MASTER RESET

The master reset is used to restore all factory defaults to the unit. It is used in the unlikely event of the unit losing or corrupting the contents of its nonvolatile memory. All user configurations will be lost.

To reset the unit to the factory defaults, hold the two outer keypad buttons down simultaneously (The DOWN and LEFT arrows) while powering up the unit. Wait two to three seconds and then release.

## APPENDIX D – RE-PROGRAMMING FIRMWARE

The operating firmware in the unit is programmed into flash memory and can be updated in the field. It is loaded from the compact flash card. User's can upgrade their firmware by simply downloading the latest firmware from the Company website, saving it onto the CompactFlash™ card, inserting the CompactFlash™ card into the unit and following the steps below.

The upgrade file is named MRUPG.hex. Once this file is on the CompactFlash™ card, insert the card into the unit and turn the power off. Press and hold the MENU button and Left Arrow (◀) simultaneously and power the unit back on.

The POWER LED will come on fully bright; the other will blink as the card is accessed. If the program is loaded successfully, the two LEDs will alternate. If the load failed, the two LEDs will blink in unison. It takes 10 to 15 seconds to load the program. If the load should fail, try it again. If it still fails, reload the file on the card.

Remove the power and re-apply it. The screen will show the latest firmware revision and build date.

## WARRANTY REPAIR POLICY

### Limited Warranty on Products

Any Cooper Instruments product which, under normal operating conditions, proves defective in material or in workmanship within one year of the date of shipment by Cooper will be repaired or replaced free of charge provided that a return material authorization is obtained from Cooper and the defective product is sent, transportation charges prepaid, with notice of the defect, and it is established that the product has been properly installed, maintained, and operated within the limits of rated and normal usage. Replacement or repaired product will be shipped F.O.B. from our plant. The terms of this warranty do not extend to any product or part thereof which, under normal usage, has an inherently shorter useful life than one year. The replacement warranty detailed here is the buyer's exclusive remedy, and will satisfy all obligations of Cooper whether based on contract, negligence, or otherwise. Cooper is not responsible for any incidental or consequential loss or damage which might result from a failure of any and all other warranties, express or implied, including implied warranty of merchantability or fitness for particular purpose. Any unauthorized disassembly or attempt to repair voids this warranty.

### Obtaining Service under Warranty

Advance authorization is *required* prior to the return to Cooper Instruments. Before returning the item, contact the Repair Department c/o Cooper Instruments at (540) 349-4746 for a Return Material Authorization number. Shipment to Cooper shall be at buyer's expense and repaired or replacement items will be shipped F.O.B. from our plant in Warrenton, Virginia. Non-verified problems or defects may be subject to a \$100 evaluation charge. Please return the original calibration data with the unit.

### Repair Warranty

All repairs of Cooper products are warranted for a period of 90 days from date of shipment. This warranty applies only to those items that were found defective and repaired; it does not apply to products in which no defect was found and returned as is or merely recalibrated. It may be possible for out-of-warranty products to be returned to the exact original specifications or dimensions.

\* Technical description of the defect: In order to properly repair a product, it is *absolutely necessary* for Cooper to receive information specifying the reason the product is being returned. Specific test data, written observations on the failure and the specific corrective action you require are needed.