

MODEL 3i - BASIC FORCE/TORQUE INDICATOR

The 3i digital force / torque indicator is designed to work with a wide range of remote force and torque sensors. With exclusive Plug & Test™ technology, all calibration and configuration data is saved within the sensor's smart connector, not the indicator, allowing for true interchangeability. In addition, all sensors are fully compatible with the advanced 5i force / torque indicator.

The 3i shares its menu structure and most specifications with Series 3 digital force gauges. The sampling rate is 2,000 Hz, producing accurate results under a wide range of test conditions. A backlit graphic LCD displays large characters, and a menu is available to access the gauges' features and configurable parameters. The display also features an analog load bar for graphical representation of applied load, as well as set point indicators for pass-fail testing. USB output is provided for data collection purposes.

The gauges include MESUR™ Lite data acquisition software. MESUR™ Lite tabulates continuous or single point data. One-click export to Excel allows for further data manipulation.

- INTERCHANGEABLE FORCE AND TORQUE SENSORS THROUGH PLUG & TEST™ TECHNOLOGY
- HIGH-SPEED 2,000 HZ SAMPLING RATE
- USB DATA OUTPUT
- ULTRA-COMPACT SIZE
- LARGE BACKLIT GRAPHIC DISPLAY
- PROGRAMMABLE SET POINTS WITH PASS/FAIL INDICATORS
- LIVE LOAD BAR GRAPH WITH SET POINT MARKERS
- PEAK READINGS AND SET POINTS ALWAYS DISPLAYED
- CONFIGURABLE AUDIO ALARMS AND KEY TONES
- 4 SELECTABLE UNITS OF MEASUREMENT
- MESUR™ LITE DATA COLLECTION SOFTWARE INCLUDED

SPECIFICATIONS

ACCURACY:	±0.2% of full scale + sensor
SAMPLING RATE:	2,000 Hz, pulse response of 1/1,000 sec. minimum
POWER:	AC or rechargeable battery. Multi-step low battery indicator is displayed, gauge shuts off automatically when power is too low.
BATTERY LIFE:	Backlight on/off: up to 7 / 24 hours of continuous use
USB OUTPUTS:	By pressing DATA key only. Configurable up to 115,200 baud.
CONFIGURABLE SETTINGS:	Digital filters, USB output, automatic shutoff, default settings, key tones, audio alarms, calibration.
WEIGHT:	0.7 lb [0.3 kg]
INCLUDED ITEMS:	Carrying case, universal voltage AC adapter, battery, quick-start guide, USB cable, resource CD (USB driver, MESUR™ Lite software, MESUR™ gauge DEMO software, and user's guide), and certificate of conformance.
WARRANTY:	3 years (see individual statement for further details)



MODEL 3i - BASIC FORCE/TORQUE INDICATOR

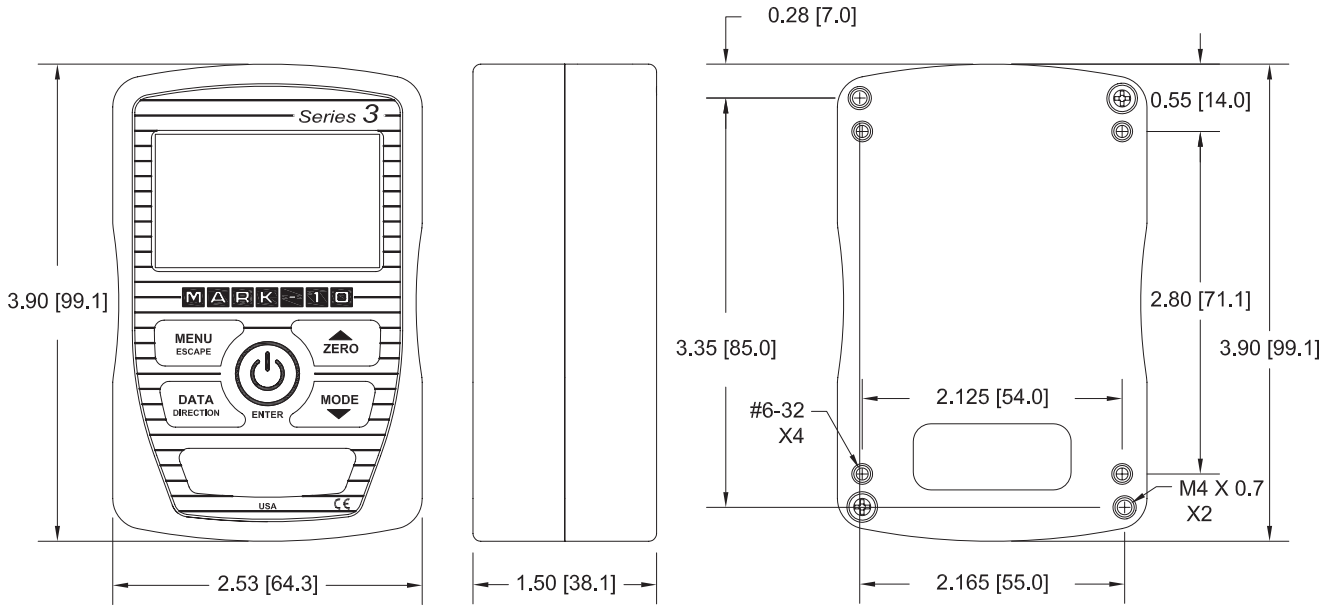

ORDERING INFORMATION

Model	Description
M3I	Advanced Force / Torque Indicator, 110V
M3IE	Advanced Force / Torque Indicator, 220V, European Plug
M3IU	Advanced Force / Torque Indicator, 220V, UK Plug
M3IA	Advanced Force / Torque Indicator, 220V, Australian Plug
AC1008	Tabletop mounting kit for 3i/5i



The Plug & Test™ connector locks into the receptacle in the indicator when fully inserted. Dual buttons on the indicator housing release the connector for easy removal. Gold plated spring contacts ensure long lasting and reliable connection.

MODEL 3i - BASIC FORCE/TORQUE INDICATOR

Models 3i and 5i force/torque indicators are designed for use with remote force and torque sensors. All calibration and configuration data is saved within the sensors' smart connectors - not the indicator - allowing for true interchangeability. Each sensor series is available in a range of capacities, from 0.25 to 10,000 lbF (1 N to 50 kN) full scale and from 10 ozFin to 5,000 lbFin (7 Ncm to 550 Nm) full scale. Refer to individual sensor data sheets for further details.

S
U
fi

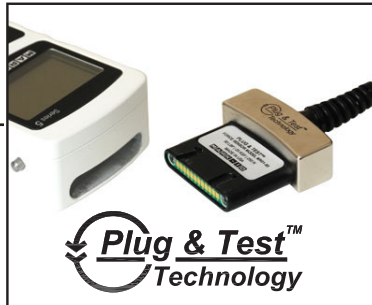

Series R01
Tension / compression sensors

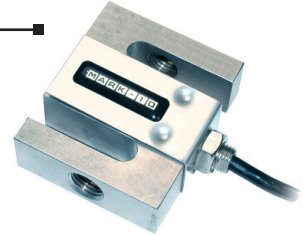

Universal torque sensors interchangeable attachments



Series R54
Wrench extension torque sensors



Model 5i
Advanced Indicator

Model 3i
Basic Indicator

Series R03
Inline tension / compression sensors



Series R52
Static torque sensors

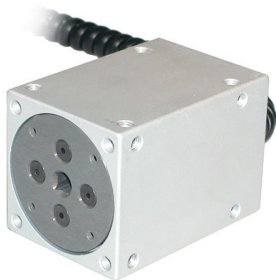

Series R05
Ergonomics testing push / pull sensors

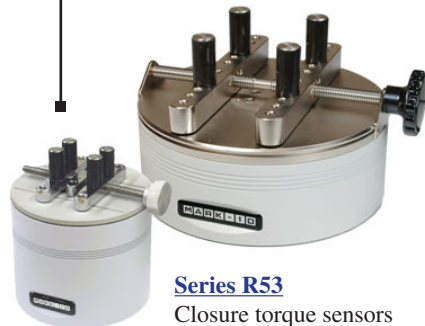

Series R53
Closure torque sensors